



#### Color Variants

BOP250102

BOP250112

BOP250132

#### Included accessories

1 x enamel baking tray,  
suit. pyrolytic clean.

1 x glass pan.

1 x grill shelf.

1 x pluggable meat probe.

#### Optional accessories

BA016105

Pull-out system

BA026115

Baking tray, enameled

BA036105

Wire rack, chromium-plated

BA046115

Glass tray

BA056115

Heating element for baking stone and  
cast-iron roaster

BA056133

Baking stone

BA226105

Broil pan, enameled

BS020002

Pizza peel, additional set of 2

GN340230

Non-stick aluminum cast-iron roaster

#### Product Variants

BOP251102

#### Product Features

##### Product color

Anthracite

##### Construction type

Built-in

##### Integrated Cleaning system

Self Clean

##### Required cutout size (HxWxD) (mm)

590-590 x 560-560 x 550

##### Overall appliance dimensions (HxWxD) (mm)

595 x 590 x 547

##### Product packaging dimensions (HxWxD) (mm)

760 x 710 x 650

##### Control Panel Material

##### Door Material - primary cavity

Glass

##### Net weight (kg)

54.843

##### Usable volume of cavity (l)

76

##### Cooking mode

Baking stone function, Bottom heat,  
Conventional heat, Defrost, Dough  
proving setting, Full width broil, Half  
width broil, Hot Air, Hot air broiling, Hot  
Air-Eco, Roasting function, Top heat

##### Primary cavity material

##### Number of interior lights

1

##### Approval certificates

Australia Standards, CE, Eurasian, G-  
Mark, Ukraine, VDE

##### Power cord length (cm)

##### Interior Lights - primary cavity

1

##### Pull-out system

Accessory

##### Timer settings

Alarm, Off, On, timer

##### Included accessories

1 x enamel baking tray, suit. pyrolytic  
clean, 1 x glass pan, 1 x grill shelf, 1 x  
pluggable meat probe

##### Bake Element Wattages primary cavity (W)

##### Broil Element Wattages primary cavity (W)

3000

##### Convection Element Wattages primary cavity (W)

2100

##### Microwave Wattages (W)

##### Drawer wattage (W)

##### Consumption and connection features

##### Energy efficiency class (2010/30/EC)

A

##### Energy consumption per cycle

##### conventional (2010/30/EC)

1.25

##### Energy consumption gas oven per cycle

##### conventional (2010/30/EC)

##### Energy consumption per cycle forced

##### air convection (2010/30/EC)

0.83

##### Energy consumption gas oven per cycle

##### forced air convection (2010/30/EC)

##### Energy efficiency index (2010/30/EC)

95.4

##### Watts (W)

3700

##### Current (A)

16

##### Volts (V)

220-240

##### Frequency (Hz)

50

##### Plug type

fixed connection, no plug

##### Connecting cable type

##### UPC code

##### Product color

Anthracite

##### Alternative colors available

BOP250112, BOP250132

##### Energy source

Electric

##### Approval certificates

Australia Standards, CE, Eurasian, G-  
Mark, Ukraine, VDE

# GAGGENAU

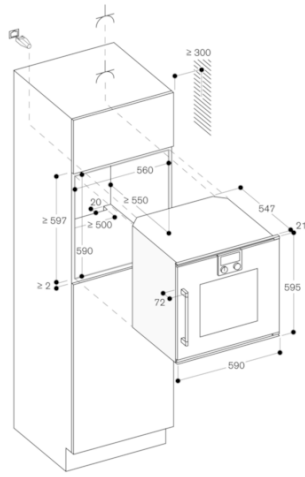

measurements in mm