

PKG3

BORA Pro gas cooktop

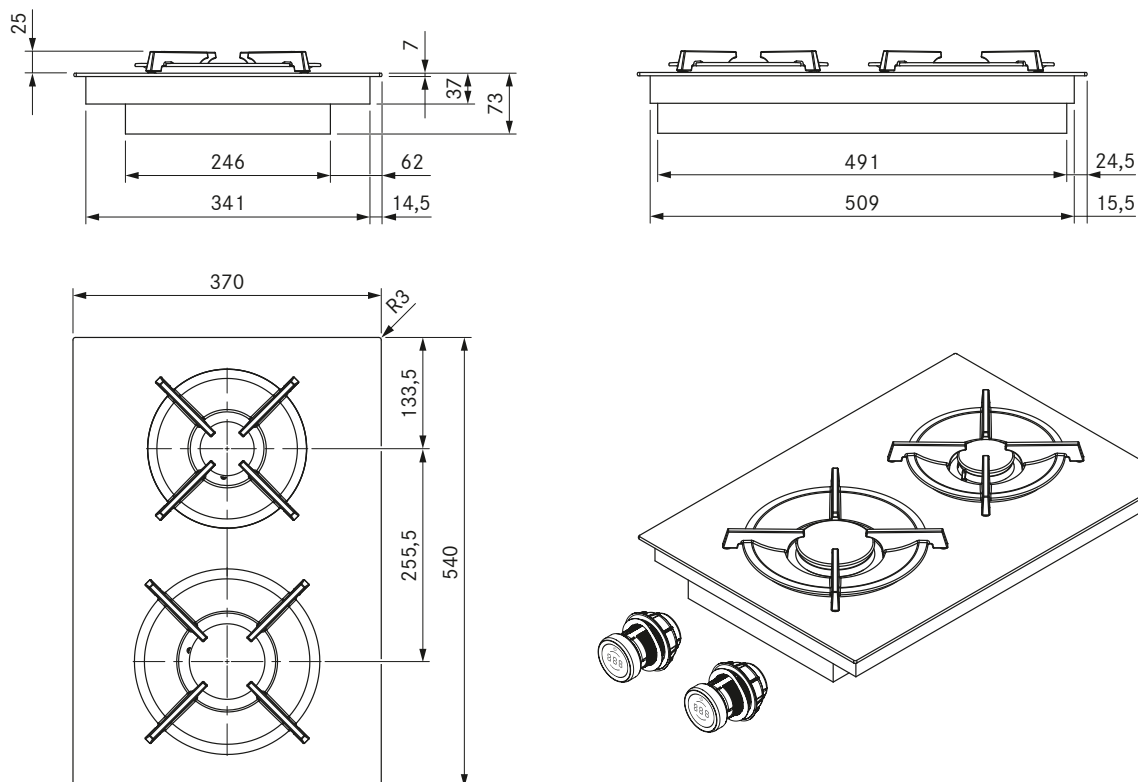

Technical data

Supply voltage	220 - 240 V
Frequency	50/60 Hz
Maximum power consumption	5.0 kW
Maximum power rating	20 W
Minimum fuse protection	1 x 0.5 A
Power supply cable length	1,5 m
Dimensions (width x depth x height)	370 x 540 x 73 mm
Weight (incl. accessories/packaging)	11.5 kg
Surface material	SCHOTT CERAN®
Cooktop power levels	1 - 9, P
Size of front cooking zone	Ø 240 mm
Size of rear cooking zone	Ø 200 mm
Front cooking zone output (power burner)	800-3000 W
Rear cooking zone output (normal burner)	550-2000 W
Size of front pan support	270 x 270 x 25/50 mm
Size of rear pan support	235 x 235 x 25/50 mm

Product description

- Intuitive control knob
- Variable heat retention function
- Sunken gas burners
- Automatic reignition
- Dishwasher-safe pan supports
- Childproofing feature
- automatic heat up function
- precise electronic control
- residual heat display
- Demo mode

Scope of delivery

- Gas cooktop PKG3
- 2 x control knobs
- 2 x connection cables for the control knobs
- 2 x cast iron pan supports
- Gas nozzle set G20/20 mbar natural gas
- Flexible gas connection tube, length 500 mm, 1/2" external thread
- Connection cable to the extractor

- operating and installation instructions
- height adjustment plate set
- mounting straps
- Adapter cylindrical-conical
- Seal

Accessories

- BORA gas nozzle set natural gas G20/10 mbar PKGDS2010
- BORA gas nozzle set natural gas G20/13 mbar PKGDS2013
- BORA gas nozzle set natural gas G20/20 mbar PKGDS2020
- BORA gas nozzle set natural gas G25/20 mbar PKGDS2520
- BORA gas nozzle set natural gas G20/25 mbar PKGDS2025
- BORA gas nozzle set natural gas G25/25 mbar PKGDS2525
- BORA gas nozzle set liquid gas G30/G31 28-30/37 mbar PKGDS3028
- BORA gas nozzle set liquid gas G30/G31 50 mbar PKGDS3050
- BORA Pro gas nozzle set liquid gas G31/G30 mbar PKGDS3130
- BORA Pro gas nozzle set liquid gas G31/50 mbar PKGDS3150
- BORA burner set PKGBS
- BORA pan support small PKGTG
- BORA pan support large PKGTG

product- and planning instructions

- Ensure sufficient air supply below the gas cooktop. Either over the front of the body (opening cross-section > 50 cm²) or over the plinth area (opening cross-section > 150 cm²)
- Provide a return flow aperture (opening cross-section > 1000 cm² per air cleaning unit) for recirculation in the plinth area
- Please note the local regulations and connection requirements applicable to gas cooktops
- Please note the special installation and workmanship guidelines for the gas cooktop (see the operating and installation instructions)
- When operating a gas cooktop with a cooktop extractor, the gas flame can be affected (depending on the height of the power level on the cooktop extractor)
- The performance characteristics of the gas cooktop (e.g. heating times, efficiency, etc.) are affected by the cooktop extractor. The cooktop extractor also affects the heat input and distribution
- If the gas cooktop is used in a model with two cooktop extractors, it is to be installed at the side
- Rotation by 180° possible during installation