

Series 8, Fully-integrated dishwasher, 60 cm, variohinge SMT8ZC801A



- **PerfectDry:** Perfect drying results with low energy consumption even with hard-to-dry items.
- **Max Flex Pro baskets:** easy loading with protection for your dishes.
- **VarioDrawer Pro:** Provides extra loading flexibility and convenience for cutlery, cups, and large utensils.
- **Height adjustable basket top basket**
- **The Silence plus dishwasher is pleasingly quiet at just 42 dB.**

Maximum number of place settings (EU 2017/1369): 15
 The water consumption of the eco programme in liters per cycle (EU 2017/1369): 12.2 l
 Built-in / Free-standing: Built-in
 Height of removable worktop: 0 mm
 Dimensions of the product (HxWxD): 815 x 598 x 550 mm
 Min. required niche size for installation (HxWxD): 815-875 x 600 x 550 mm
 Depth with open door 90 degree: 1150 mm
 Adjustable feet: Yes - all from front
 Maximum adjustability feet: 60 mm
 Adjustable plinth: Both horizontal and vertical
 Net weight: 47.6 kg
 Gross weight: 49.5 kg
 Connection rating: 2400 W
 Fuse protection: 10 A
 Voltage: 220-240 V
 Frequency: 50; 60 Hz
 Length electrical supply cord: 175.0 cm
 Plug type: AU plug
 Length inlet hose: 165 cm
 Length outlet hose: 190 cm
 EAN code: 4242005400225
 Installation type: Integrated

SGZ0BI11	decorative strips stainless steel 86,5cm
SGZ1010	inlet and outlet hose extention
SGZ8BI00	Connection rail for divided furniture
SMZ2014	Rack insert for stemware dishwasher
SMZ5045	Decor conversion kit, stainless steel
SMZ5150AU	Kick panel stainless steel
SMZ5300	GlassSecure Tray



Series 8, Fully-integrated dishwasher, 60 cm, variohinge SMT8ZC801A

Capacity

- 15 place setting capacity

Consumption rates

- 4.5 Energy rating
- 5,0 stars WELS Water rating
- Water consumption: 12.2 litres per wash with Cold water connection using the Eco Wash in accordance with AS/NZS 6400. AU WELS Registration Number: D02845. Energy consumption: 206 kWh per year, with Cold water connection using the Eco Wash program seven times per week. When tested in accordance with AS/NZS 2007.2. Actual energy use and running costs will depend on how you use the appliance.

Design

- Stainless steel interior tub with 10 year rust through warranty
- Max Flex Pro basket system with red coloured touchpoints, easy to identify flexing & moving parts
- Gap Illumination: The gap between the dishwasher door and kitchen cabinetry (upper left) discreetly glows when the dishwasher is in operation
- High definition Full Colour TFT display screen
- Touch Control interface
- Hidden control buttons integrated into the top of the door
- Vario Hinge: The door hinge allows the decorative door panel to slide upwards while opening, allowing for reduced plinth height (minimum 5cm)

Wash Programs and Options

- 8 Wash Programs:
 - Eco Wash : Energy efficient wash & dry. Mixed loads & soil levels
 - Auto Intensive
 - Auto Wash
 - Auto Gentle
 - Short wash: quick wash & dry. Mixed loads & soil levels. 89 mins
 - Express wash: Wash only for lightly soiled dishes
 - ExtraQuiet: extended quiet wash & dry program for mixed loads & soil levels
 - Favourite: set or download your favourite combination (Pre-Rinse is set as default)
- 5 special options:
 - Remote Start: Connect to WiFi via HomeConnect
 - Extra Dry: Provides an even better drying result by extending the drying time.
 - Intensive Zone
 - HygienePlus: Hotter final rinse, for increased hygiene that helps to remove bacteria
 - SpeedPerfect
 - Machine Care: Maintains your dishwasher's optimum performance and hygiene

Performance

- PerfectDry: A unique and energy efficient drying technology that harnesses the power of Zeolith which absorb moisture molecules to provide table ready, streak free glass and tableware. Perfect for drying items that are usually very difficult to dry in a dishwasher such as plastics and sensitive glassware

- DosageAssist: Maximises the effectiveness of detergent tablets. The tablet is dropped into a specially engineered tray and is completely dissolved. For superior cleaning performance and a quieter wash
- Extra Clean Zone: Provides an even better cleaning result for items placed directly over the three rotating nozzles in the top basket
- AutoBrilliance: Automatic detergent and rinse aid sensor
- Quiet operation: 42 dB(A)
- Extra Quiet program noise level: 40 dB(A)
- EcoSilence Drive quiet and energy-efficient brushless motors (BLDC): Main Pump & Drain Pump. Variable water & spray pressure to achieve optimum cleaning results. Fast and extra quiet draining of water, no gargling sounds
- 3 stage filter system, including an innovative micro filter with a corrugated design that conveniently helps to reduce the need to wash the filter and also helps to prevent blockages.
- 5 spray levels for maximum water contact and optimum wash results

Flexibility

- VarioDrawer™ Pro: Third loading level for cutlery & utensils
- Ball bearing wheels on all loading levels for easy and smooth basket gliding, even when fully loaded
- Rack Stopper to prevent derailing of bottom basket
- 6 foldable plate racks in top basket
- 8 foldable plate racks in bottom basket
- 2 foldable cup shelves with soft silicone edges in top basket
- Moveable cutlery basket in bottom basket
- Glass rack in bottom basket for tall stemmed glasses
- Heat Exchanger: Hygienic fully enclosed drying system - does not draw contaminated air (dust & allergens) from the dishwasher exterior. Reduces temperature shock, water & energy use.
- Rackmatic: the top basket can be adjusted to at various height levels to maximise convenience, and even utilised on an angle which helps prevent water pooling on the top of cups

Convenience

- DoorOpen Assist - a push to open door system, perfect for handleless kitchens
- Time delay start: Delay program start time by 1-24 hours to suit your schedule
- Home Connect WiFi connectivity
- Large item spray head: For washing extra large items such as baking trays and rangehood filters
- Vapor barrier plate included
- Audible program end indicator tone (can be turned on/off)

Safety

- AquaStop Plus: Water supply device with lifetime anti-flood protection
- Child door lock (double push to open)

Appliance dimensions and weight

- Packaging dimensions (HxWxD): 88 cm x 66 cm x 67 cm
- Appliance dimensions (HxWxD): 81.5-87.5 cm x 59.8 cm x 55 cm
- Gross Weight: 49.5 kg

**Series 8, Fully-integrated
dishwasher, 60 cm, variohinge
SMT8ZC801A**

measurements in mm

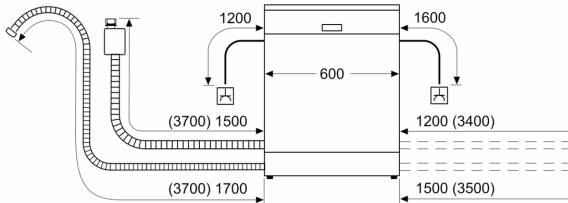

⌚ socket
() values with extension kit

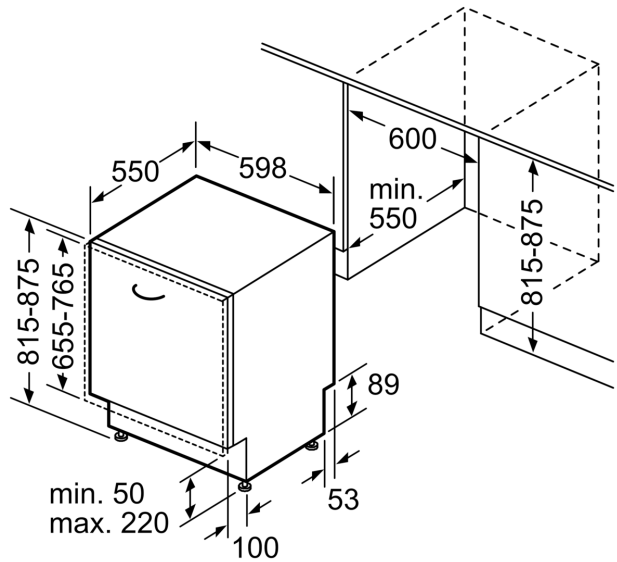

measurements in mm