

N 90, Built-in compact oven with microwave function, Width
60 cm
C27MS22H0B



Features

Technical Data

Type of micro-wave oven : MW-Combi
Type of control : Electronic
Color / Material Front : Stainless steel
Dimensions : 455 x 596 x 548
Cavity dimensions (mm) : 237.0 x 480 x 392.0
Length electrical supply cord (cm) : 150
Net weight (kg) : 35.733
Gross weight (kg) : 38.0
EAN code : 4242004236528
Maximum micro-wave power (W) : 900
Connection Rating (W) : 3600
Current (A) : 16
Voltage (V) : 220-240
Frequency (Hz) : 50; 60
Plug type : no plug



4 242004 236528

Optional accessories

Z11SZ00X0 SeamlessCombination mounting kit
Z11SZ60X0
Z11SZ90X0
Z12CB10A0 Baking tray, anthracite enamelled
Z12CM10A0 Moussaka pan, anthracite enamelled
Z14CR10X0
Z1913X0 Baking Stone
Z19DD10X0 Steam set for ovens

*N 90, Built-in compact oven with microwave
function, Width 60 cm
C27MS22H0B*

Features

Heating Functions

- Compact oven with microwave with 12 heating methods: CircoTherm / HotAir CircoTherm Eco Top/Bottom heat Top/Bottom heat Eco CircoRoasting Full surface grill Centre area grill CircoTherm Intensive / Pizza setting Bottom heat Low temperature / slow cooking Dough proving Plate warming
- Additional heating methods with microwave: Microwave, 5 power levels Combination microwave and conventional oven
- Temperature range 30 °C - 300 °C
- Max. Power: 900 W; 5 Microwave power settings (90 W,180 W,360 W,600 W,900 W) with Inverter (MW)
- Intelligent inverter technology: maximum output power will be regulated to 600 W when used in longer operation
- Cavity volume: 45 l

Design

- Illuminated ShiftControl
- Anthracite enamel cavity with 3 shelf positions

Cleaning

- Pyrolytic self cleaning
- EasyClean Cleaning program

Convenience

- 4.1" TFT colour and graphics display with ShiftControl
- Temperature proposal Actual temperature display Optical temperature control Sabbath setting
- SoftMove Door - SoftOpen & SoftClose
- Supporting systems: Bake and Roast assist, Automatic Programs
- Number of automatic programs: 14
- Electronic clock with start / stop function
- Rapid heating-up
- LED lighting
- Cooling fan
- Stainless-steel fan
- Individual adjustable child lock Residual heat indicator Safety switch off
- HomeConnect ready on WLAN

Accessories

- 1 x combination grid, 1 x universal pan

Technical Information

- Length of mains cable: 150 cm
- Total connected load electric: 3.6 KW
- Appliance dimension (HxWxD): 455 mm x 596 mm x 548 mm
- Installation dimensions (HxWxD): 450 mm - 455 mm x 560 mm - 568 mm x 550 mm
- Please reference the built-in dimensions provided in the installation drawing

N 90, Built-in compact oven with microwave function, Width 60 cm
C27MS22H0B

Dimensioned drawings

Installation with a hob.

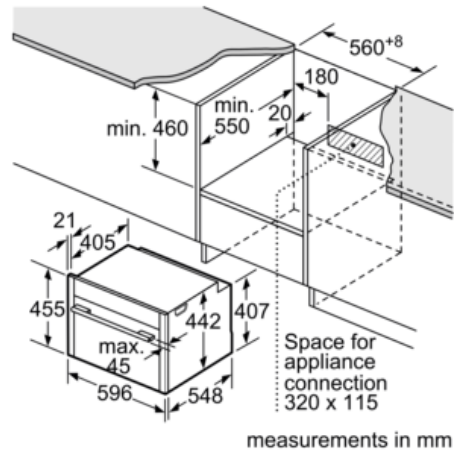
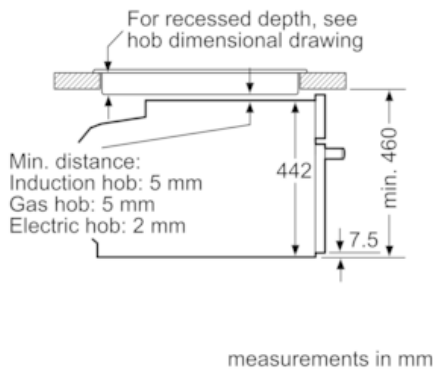

If the compact appliance will be installed underneath a hob, the following worktop thicknesses (including substructure if necessary) must be taken into account.

Hob type	min. worktop thickness	
	fitted	flush
Induction hob	42 mm	43 mm
Full surface Induction hob	52 mm	53 mm
Gas hob	32 mm	43 mm
Electric hob	32 mm	35 mm

