

Miele



CLEANSTEEL FRESH BEAN COFFEE MACHINE

CVA 6800

Built-in coffee machine with fresh bean system - the Miele all-rounder for the highest demands. Motorised spout height adjustment with CupSensor. CleanSteel finish.

- Perfect results and intense coffee flavour – AromaticSystem
- Fully automatic perfection – OneTouch for Two
- Unique automatic sensing of cup height – CupSensor
- Innovative and convenient milk system – EasyClick milk system
- Easy cleaning for care and maintenance – Cleaning programmes

SPECIFICATIONS

Dimensions:

44.8-45.2 cm (h) x 56-56.8 cm (w) x 55 cm (d)

Model overview:

- 2.3 l water tank
- Capacity for 500 g of coffee beans
- Full touch M Touch controls with full colour touch sensitive TFT display
- AromaticSystem - Perfect results and intense coffee flavour
- OneTouch for Two - Extra programme for preparing one or two espresso, coffee, cappuccino, etc.
- CupSensor - Unique automatic sensing of cup height
- EasyClick milk system - Innovative and convenient milk system
- Cleaning programmes - Easy cleaning for care and maintenance
- Pre-ground coffee facility
- Glass milk flask
- Motorised spout height adjustment

IMPORTANT: Please measure your appliance cavity prior to purchase to ensure your chosen appliance will fit. A restocking fee may apply for returned appliances due to incorrect size purchase.

Miele

CLEANSTEEL FRESH BEAN COFFEE MACHINE

CVA 6800 INSTALLATION DRAWING



* appliances with glass front

** Appliances with metal front

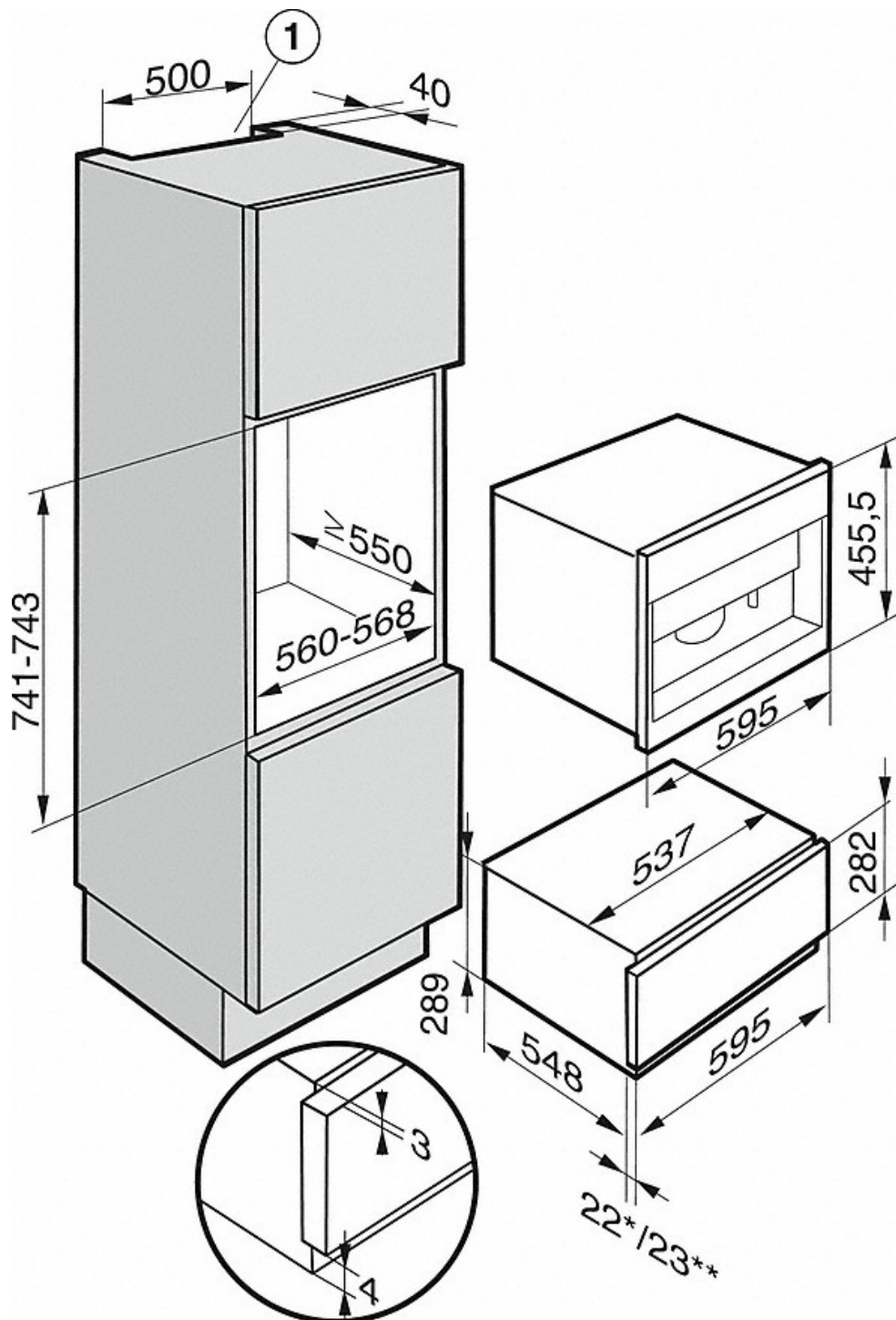

Miele

CLEANSTEEL FRESH BEAN COFFEE MACHINE

CVA 6800 INSTALLATION DRAWING



* appliances with glass front

** Appliances with metal front

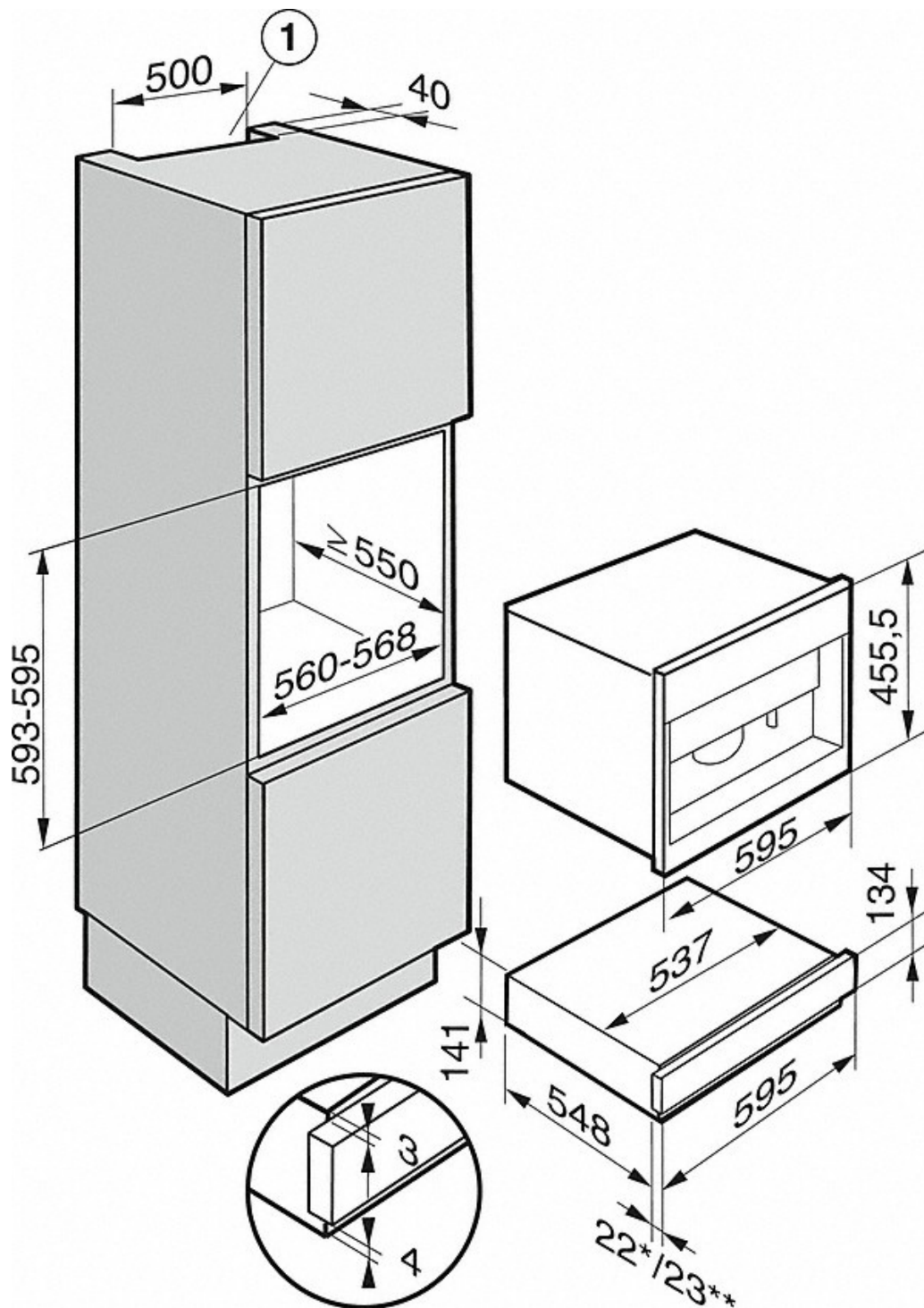

Miele



CLEANSTEEL FRESH BEAN COFFEE MACHINE

CVA 6800 SIDE VIEW INSTALLATION DRAWING

* appliances with glass front

** Appliances with metal front

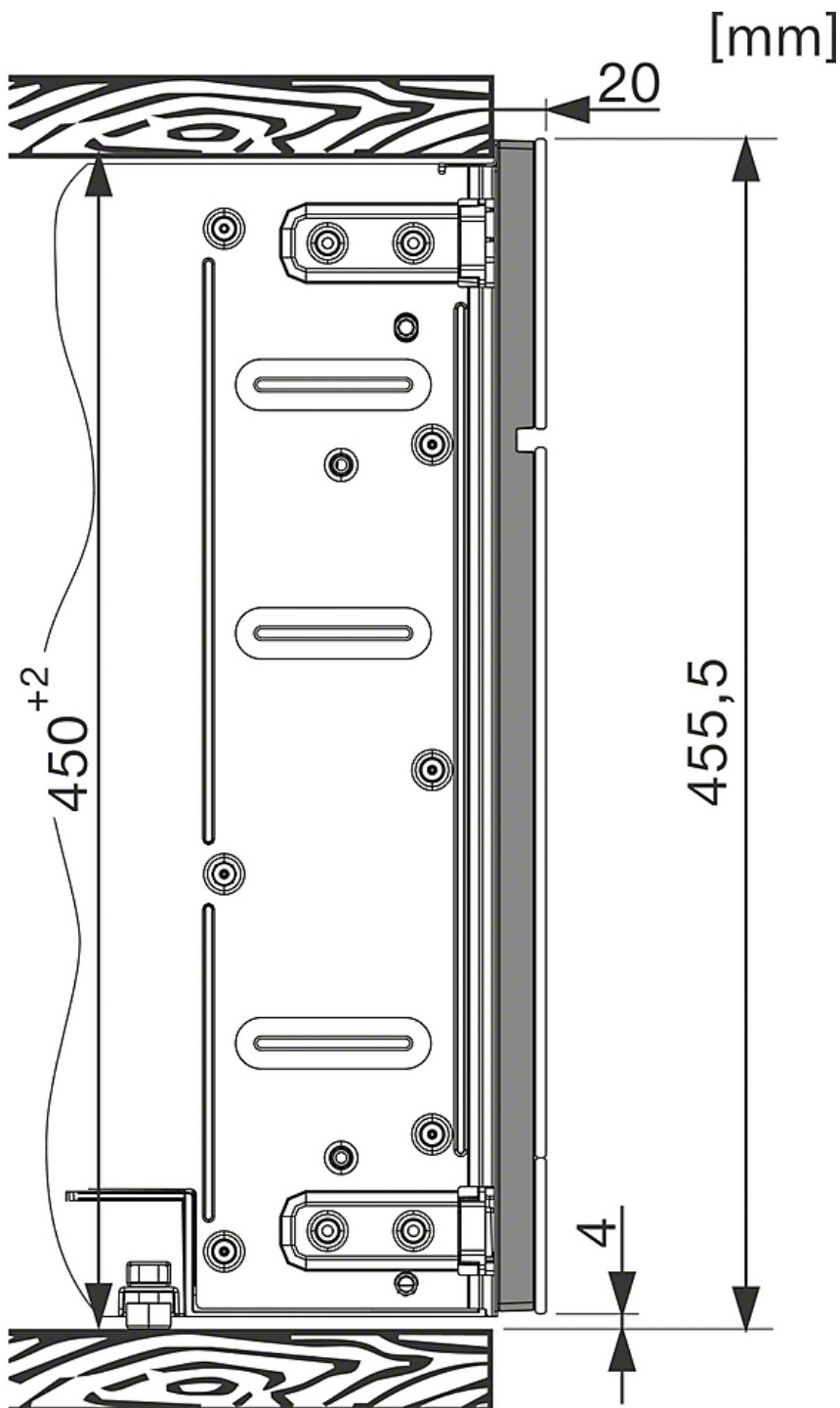

Miele

CLEANSTEEL FRESH BEAN COFFEE MACHINE

CVA 6800 INSTALLATION DRAWING



* appliances with glass front

** Appliances with metal front

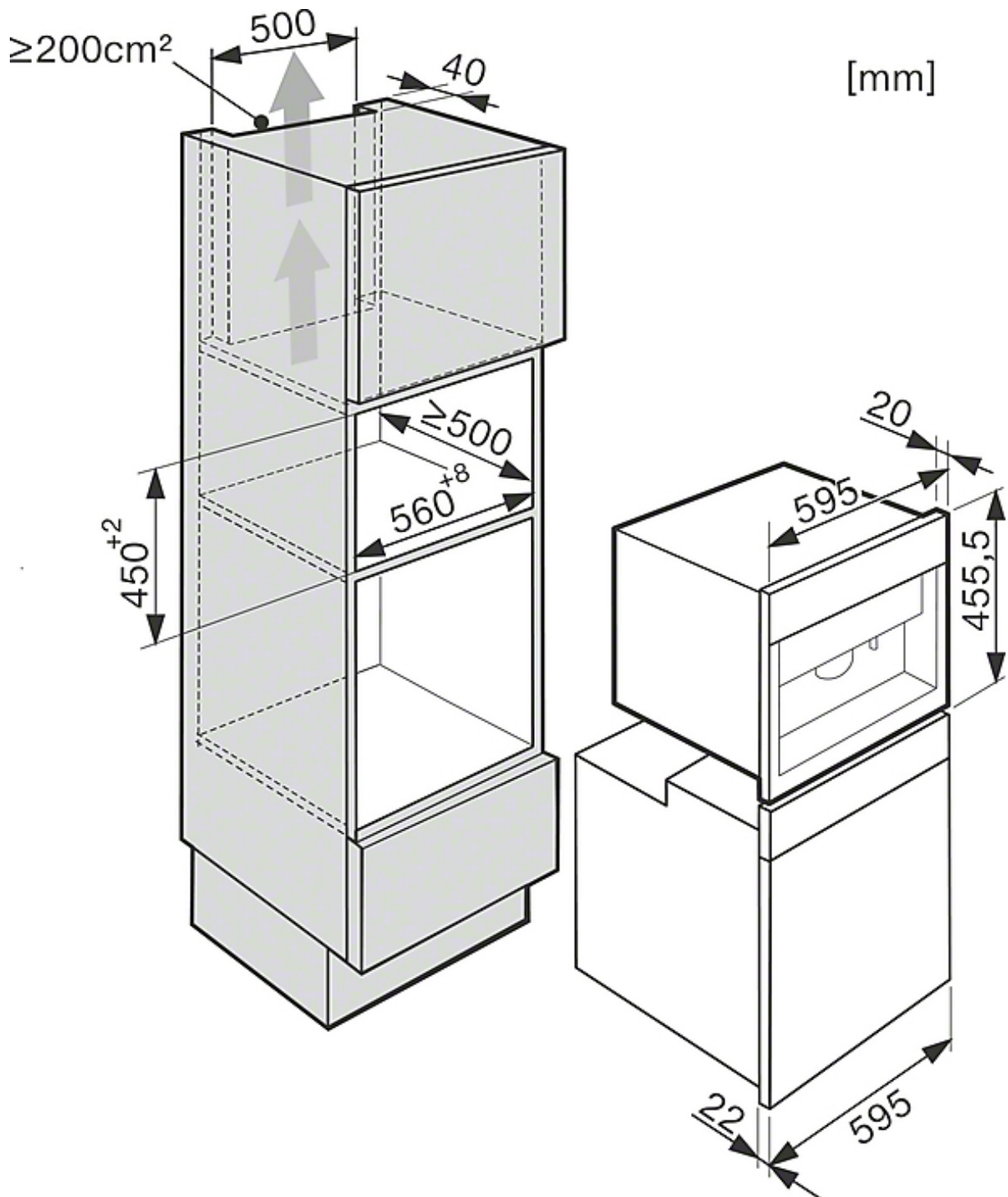

Miele

CLEANSTEEL FRESH BEAN COFFEE MACHINE

CVA 6800 INSTALLATION DRAWING



* appliances with glass front

** Appliances with metal front

