

N 90, Wall-mounted canopy rangehood, 90 cm, Stainless steel
D96BMU5N0A



Flat design in a modern shape - our classic design hood 'box'.

Features

Technical Data

Typology : Chimney
Approval certificates : Australia Standards, VDE
Length electrical supply cord (cm) : 130
Height of the chimney (mm) : 582-908/568-1018
Height of product, without chimney (mm) : 46
Minimum distance above an electric hob : 550
Minimum distance above a gas hob : 650
Net weight (kg) : 19.809
Type of control : Electronic
Number of speed settings : 3-stage + 2 intensive
Maximum output air extraction (m³/h) : 430
Boost position output recirculating (m³/h) : 385.0
Maximum output recirculating air (m³/h) : 311
Boost position air extraction (m³/h) : 843
Number of lights : 3
Noise level (dB) : 55
Diameter of air outlet (mm) : 120 / 150
Grease filter material : Washable stainless steel
EAN code : 4242004235965
Connection Rating (W) : 165
Current (A) : 10
Voltage (V) : 220-240
Frequency (Hz) : 50; 60
Plug type : AU plug
Installation typology : Wall-mounted

Optional accessories

Z5102X1	Standard odor filter (replacement)
Z5102X5	Standard recirculation kit



4 242004 235965

*N 90, Wall-mounted canopy rangehood, 90 cm,
Stainless steel
D96BMU5N0A*

Features

Design & Innovation

- Box brand design
- For wall mounted installation
- Appliance colour: Stainless steel
- Suitable for ducted extraction and recirculation
- Accessories required for recirculated extraction: Recirculating kit
- EASY Installation
- Appliance width: 898 mm
- Electronic controls
- 3 power levels + 2 intensive levels
- Extraction rate according to EN 61591 ø 15 cm: max. Normal use 430 m³/h Intensive 843 m³/h
- Extraction rate in recirculation mode: Max. normal use: 311 m³/h Intensive: 385 m³/h
- Noise min./max. Normal Level: 46/55 dB
- Efficient BLDC-technology

Convenience

- Automatic Air Sensor
- Automatic intensive revert setting - 6 min
- Automatic run on for Automatic run on - 10 min
- 3 x 1.5 Watt LED Lights
- Softlight with dimming function
- Saturation display for filters
- Stainless steel filter covers, dishwasher safe
- Additional noise insulation mats for optimised sound absorption
- Energy Efficiency Class: A+ (at a range of energy efficiency classes from A++ to E)
- with one-way flap

Technical Information

- Dimensions exhaust air (HxWxD): 614-954 x 898 x 500 mm
- Dimensions recirculating (HxWxD): 614-1064 x 898 x 500 mm
- Diameter pipe Ø 150 mm (Ø 120 mm enclosed)
- Power rating: 165 W
- Electrical cable length 1.3 m
- Voltage: 220 - 240 V

N 90, Wall-mounted canopy rangehood, 90 cm,
Stainless steel
D96BMU5N0A

Dimensioned drawings

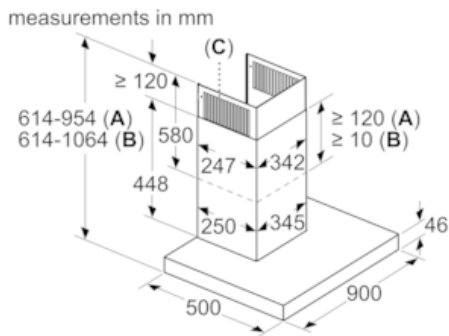

- A: Air extraction
- B: Air recirculation
- C: Air outlet – slots for exhaust air to be mounted facing down

