

DAR 1130

Extractor unit

for perfectly combining with Range Cookers or Range Tops.



- Customised kitchen design – fully integrated in 850mm
- Perfect illumination – LED ClearView lighting
- Dishwasher-proof – 3 high-quality stainless steel grease filters
- Safe and easy to clean – Miele CleanCover
- Temperature sensor – protects against overheating

Construction type	
Integrated extractor	•
Operating modes	
Type of air guide	air extraction
User convenience	
Electronic controls	•
Rotary knob	•
Power levels (number without Booster level)	3
Booster level	•
Temperature sensor	•
Cleaning convenience	
Easy-to-clean canopy interior – CleanCover	•
Filter system	
Number of dishwasher-safe stainless steel filters	3
Lighting	
LED	•
Air throughput with max. duct diameter in extraction mode (not for external version)	
Air throughput in Level 1 (m ³ /h)	950
Air throughput in Level 2 (m ³ /h)	1,350
Air throughput in Level 3 (m ³ /h)	1,550
Air throughput in Booster level (m ³ /h)	1,700
Safety	
Safety switch-off	•
Technical data	
Canopy width in mm	850
Canopy height in mm	449
Canopy depth in mm	579
Net weight in kg	19.0
Length of supply lead in m	0.8
Standard plug fitted	•
Total rated load in kW	0.73
Voltage in V	230
Fuse rating in A	10
Number of phases	1
Installation notes	
Extraction ducting connection at top	•
Extraction ducting connection at rear	•
Extraction connection at top and rear	•
Diameter of extraction ducting connection in mm	250
Standard accessories	
Non-return flap	•

DAR 1130

Extractor unit

for perfectly combining with Range Cookers or Range Tops.

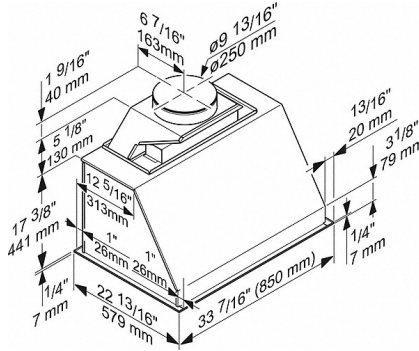

DAR1130 (installation drawing)