

DA 2450

Extractor unit

with energy-efficient LED lighting and rotary dials for easy use



- Customised kitchen design – fully integrated in 532mm width
- Powerful – 590m³/h on the booster setting
- Efficient filtration – 10-layer stainless-steel grease filter
- Safe and easy to clean – Miele CleanCover
- Suitable for every home – for extraction or recirculation

Construction type	
Integrated extractor	•
Design	
Colour	Stainless steel
Customisation possible on request	•
Operating modes	
Type of air guide	Convertible
Active charcoal filter (order separately)	DKF15-1
User convenience	
Electronic controls	•
Rotary knob	•
Power levels (number without Booster level)	2
Booster level	•
Cleaning convenience	
Easy-to-clean canopy interior – CleanCover	•
Filter system	
Number of dishwasher safe stainless steel grease filters	1
Lighting	
LED	•
Light intensity in Lx	330
Colour temperature in K	3,000
Fan	
Dual-action fan	•
AC motor	•
Air throughput with max. duct diameter in extraction mode (not for external version)	
Air throughput in Level 1 (m ³ /h)	230
Air throughput in Level 2 (m ³ /h)	350
Air throughput in Booster level (m ³ /h)	590
Sound power in Level 1 (dB(A) re 1 pW)	47
Sound power in Level 2 (dB(A) re 1 pW)	54
Sound power in Booster level (dB(A) re 1 pW)	66
Sound pressure in Level 1 (dB(A) re 20 µPa)	32
Sound pressure in Level 2 (dB(A) re 20 µPa)	40
Sound pressure in Booster level (dB(A) re 20 µPa)	52
Air throughput in recirculation mode	
Air throughput in Level 1 (m ³ /h)	185
Air throughput in Level 2 (m ³ /h)	305
Air throughput in Booster level (m ³ /h)	525
Sound power in Level 1 (dB(A) re 1 pW)	52
Sound power in Level 2 (dB(A) re 1 pW)	61
Sound power in Booster level (dB(A) re 1 pW)	71
Sound pressure in Level 1 (dB(A) re 20 µPa)	38
Sound pressure in Level 2 (dB(A) re 20 µPa)	47
Sound power in Booster level (dB(A) re 1 pW)	57

DA 2450

Extractor unit

with energy-efficient LED lighting and rotary dials for easy use



Technical data	
Canopy width in mm	532
Canopy height in mm	50
Canopy depth in mm	372
Net weight in kg	10.2
Length of supply lead in m	1.5
Standard plug fitted	•
Total rated load in kW	0.23
Voltage in V	230
Fuse rating in A	10
Number of phases	1
Installation notes	
Extraction ducting connection at top	•
Extraction connection at top and rear	•
Diameter of extraction ducting connection in mm	150
Standard accessories	
Non-return flap	•
Adapter to reduce ducting diameter from 150 mm to 125 mm Ø	•

DA 2450

Extractor unit

with energy-efficient LED lighting and rotary dials for easy use

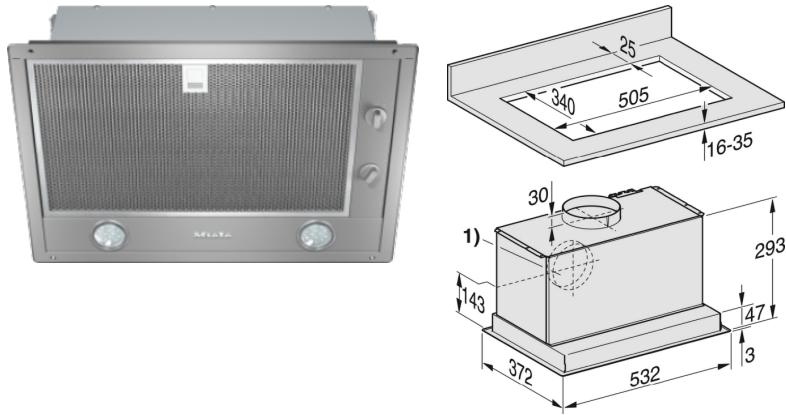

DA 2450, DA 2558 (Installation drawing)

1) Vent connection alternatively to rear