

DA 2518

Extractor unit

with energy-efficient LED lighting and light-touch switches for easy use.



- Customised kitchen design – fully integrated in 1,102mm width
- Unique user convenience – Con@ctivity
- Powerful – 785m³/h on the booster setting
- Efficient filtration – 10-layer stainless-steel grease filter
- Safe and easy to clean – Miele CleanCover

Construction type	
Integrated extractor	•
Design	
Colour	Stainless steel
RAL colours available as customisation on request	•
Customisation possible on request	•
Operating modes	
Type of air guide	Convertible
Active charcoal filter (order separately)	DKF15-1
User convenience	
Networking with Miele@home	•
Automatic function Con@ctivity 3.0 (WiFi)	•
Electronic controls	•
Light-touch controls	•
Miele@mobile app	•
Power levels (number without Booster level)	3
Booster level	•
Programmable Booster level switch-off	•
Run-on time 5 / 15 min.	•
Grease filter saturation indicator programmable	•
Active charcoal filter saturation indicator programmable	•
Cleaning convenience	
Easy-to-clean canopy interior – CleanCover	•
Filter system	
Number of dishwasher safe stainless steel grease filters	3
Lighting	
LED	•
Light intensity in Lx	520
Colour temperature in K	3,000
Fan	
Dual-action fan	•
AC motor	•

DA 2518

Extractor unit

with energy-efficient LED lighting and light-touch switches for easy use.



Air throughput with max. duct diameter in extraction mode (not for external version)	
Air throughput in Level 1 (m ³ /h)	290
Air throughput in Level 2 (m ³ /h)	425
Air throughput in Level 3 (m ³ /h)	575
Air throughput in Booster level (m ³ /h)	785
Sound power in Level 1 (dB(A) re 1 pW)	48
Sound power in Level 2 (dB(A) re 1 pW)	55
Sound power in Level 3 (dB(A) re 1 pW)	63
Sound power in Booster level (dB(A) re 1 pW)	70
Sound pressure in Level 1 (dB(A) re 20 µPa)	35
Sound pressure in Level 2 (dB(A) re 20 µPa)	42
Sound pressure in Level 3 (dB(A) re 20 µPa)	50
Sound pressure in Booster level (dB(A) re 20 µPa)	57
Air throughput in recirculation mode	
Air throughput in Level 1 (m ³ /h)	250
Air throughput in Level 2 (m ³ /h)	375
Air throughput in Level 3 (m ³ /h)	500
Air throughput in Booster level (m ³ /h)	625
Sound power in Level 1 (dB(A) re 1 pW)	59
Sound power in Level 2 (dB(A) re 1 pW)	65
Sound power in Level 3 (dB(A) re 1 pW)	70
Sound power in Booster level (dB(A) re 1 pW)	74
Sound pressure in Level 1 (dB(A) re 20 µPa)	46
Sound pressure in Level 2 (dB(A) re 20 µPa)	52
Sound pressure in Level 3 (dB(A) re 20 µPa)	57
Sound power in Booster level (dB(A) re 1 pW)	61
Safety	
Safety switch-off	•
Technical data	
Canopy width in mm	1,102
Canopy height in mm	50
Canopy depth in mm	402
Net weight in kg	14.3
Length of supply lead in m	1.5
Standard plug fitted	•
Total rated load in kW	0.31
Voltage in V	230
Fuse rating in A	10
Number of phases	1

DA 2518

Extractor unit

with energy-efficient LED lighting and light-touch switches for easy use.



Installation notes	
Extraction ducting connection at top	•
Extraction connection at top and rear	•
Diameter of extraction ducting connection in mm	150
Combination with WiFi-enabled Miele hob	recommended
Standard accessories	
Non-return flap	•
Adapter to reduce ducting diameter from 150 mm to 125 mm Ø	•
RF Con@ctivity 2.0 communication stick for KM	XKS 3000 Z

DA 2518

Extractor unit

with energy-efficient LED lighting and light-touch switches for easy use.

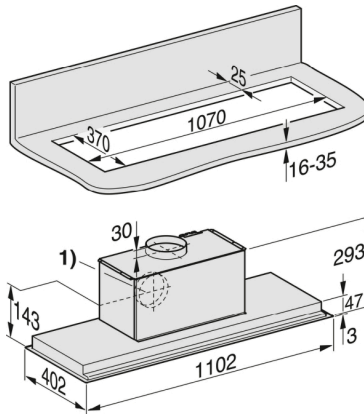

DA 2518 (Installation drawing)

1) Vent connection alternatively to rear