

Miele



CLEAN STEEL STEAM COMBINATION OVEN W.600

DGC 6400

Steam combination oven combining all the advantages of a steam oven with a conventional fan oven. 100+ Automatic Programmes and PerfectClean refined for easy cleaning. CleanSteel finish.

- Perfect results thanks to MultiSteam technology
- Sets new standards for brilliance & user convenience – M Touch
- Highest convenience – roasting with the wireless food probe
- Convenient – water container is behind a motorised control panel
- Plenty of space to be creative – the XL cooking compartment

SPECIFICATIONS

Dimensions:

44.8-45.2 cm (h) x 56-56.8 cm (w) x 55.5 cm (d)

Total rated load: 3.2 kW

Model Overview:

- 48 l capacity
- M Touch controls with full colour touch sensitive TFT display
- 3-in-1 appliance
- 100% steam
- Perfect results thanks to MultiSteam technology
- Convenient - water container is behind motorised lift-up panel
- Oven functionality
- 100% oven functionality with 10 oven functions
- 100% steam combination oven with FanPlus
- Grill or Conventional heat combination modes
- 150+ automatic programmes
- Humidity sensor
- Highest convenience - roasting with the wireless food probe
- PerfectClean
- Plenty of space to be creative - theXL cabinet

IMPORTANT: Please measure your appliance cavity prior to purchase to ensure your chosen appliance will fit. A restocking fee may apply for returned appliances due to incorrect size purchase.

Miele



CLEAN STEEL STEAM COMBINATION OVEN W.600

DGC 6400 INSTALLATION DRAWINGS

* Appliances with glass front

** Appliances with metal front

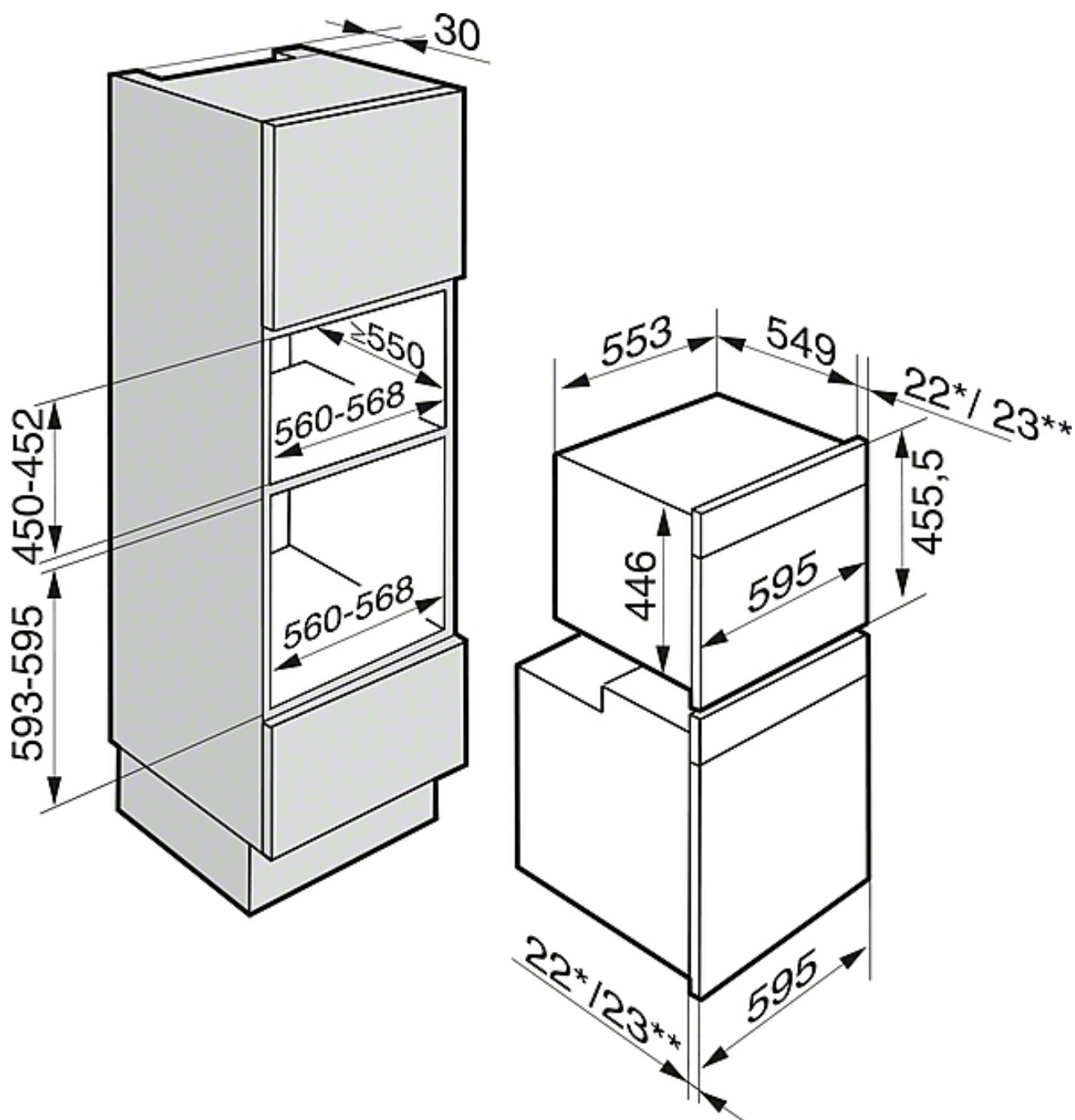

Miele

