

Miele



M TOUCH STEAM COMBINATION OVEN W.600

DGC 6800 XL

Extra large steam combination oven with M touch controls, 48 litre capacity, 3-in-1 appliance, 150+ Automatic Programmes and wireless food probe. Obsidian black finish.

- Handleless kitchen and convenient door opening – Touch2Open
- Perfect results thanks to MultiSteam technology
- Multicoloured TFT touch display with clear text – M Touch
- Perfect cooking w. precise temp. control – wireless food probe

SPECIFICATIONS

Dimensions:

44.8-45.2 cm (h) x 56-56.8 cm (w) x 55.5 cm (d)

Total rated load: 3.4 kW

Model Overview:

- 48 l capacity
- Plumbed in version
- M Touch controls with full colour touch sensitive TFT display
- 3-in-1 appliance
- 100% steam
- Perfect results thanks to MultiSteam technology
- Convenient - water container is behind motorised lift-up panel
- Oven functionality
- 100% oven functionality with 10 oven functions
- 100% steam combination oven with FanPlus
- Grill or Conventional heat combination modes
- 150+ automatic programmes
- Humidity sensor
- Highest convenience - roasting with the wireless food probe
- PerfectClean
- Plenty of space to be creative - theXL cabinet

IMPORTANT: Please measure your appliance cavity prior to purchase to ensure your chosen appliance will fit. A restocking fee may apply for returned appliances due to incorrect size purchase.

Miele

M TOUCH STEAM COMBINATION OVEN W.600

DGC 6800 XL INSTALLATION DRAWINGS



* Appliances with glass front

** Appliances with metal front

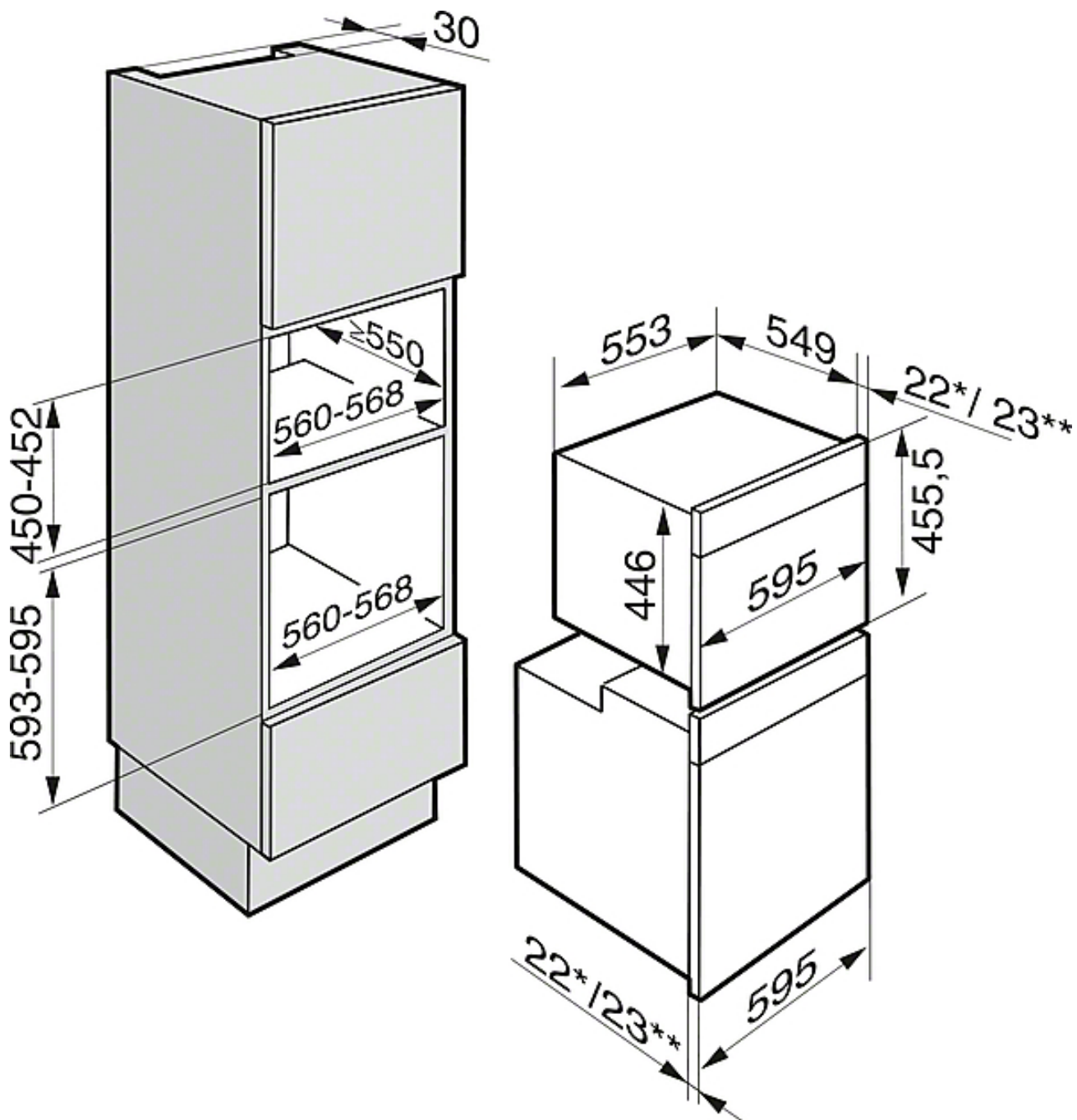

Miele

