

Miele



CLEAN STEEL STEAM COMBINATION OVEN W.600

DGC 6805 XL

Easy to use extra large steam combination oven with mains water connection. M Touch controls with full-colour sensitive TFT display, 150+ Automatic Programmes, humidity sensor. CleanSteel finish.

- Perfect results thanks to MultiSteam technology
- Sets new standards for brilliance & user convenience – M Touch
- Highest convenience – roasting with the wireless food probe
- Maximum user and cleaning convenience – fresh water connection
- Plenty of space to be creative – the XL cooking compartment

SPECIFICATIONS

Dimensions:

44.8-45.2 cm (h) x 56-56.8 cm (w) x 55.5 cm (d)

Total rated load: 3.4 kW

Model Overview:

- 48 l capacity
- Plumbed in version
- M Touch controls with full colour touch sensitive TFT display
- 3-in-1 appliance
- 100% steam
- Perfect results thanks to MultiSteam technology
- Convenient - water container is behind motorised lift-up panel
- Oven functionality
- 100% oven functionality with 10 oven functions
- 100% steam combination oven with FanPlus
- Grill or Conventional heat combination modes
- 150+ automatic programmes
- Humidity sensor
- Highest convenience - roasting with the wireless food probe
- PerfectClean
- Plenty of space to be creative - the XL cabinet

IMPORTANT: Please measure your appliance cavity prior to purchase to ensure your chosen appliance will fit. A restocking fee may apply for returned appliances due to incorrect size purchase.

Miele

CLEAN STEEL STEAM COMBINATION OVEN W.600

DGC 6805 XL | INSTALLATION DRAWINGS



* Appliances with glass front

** Appliances with metal front

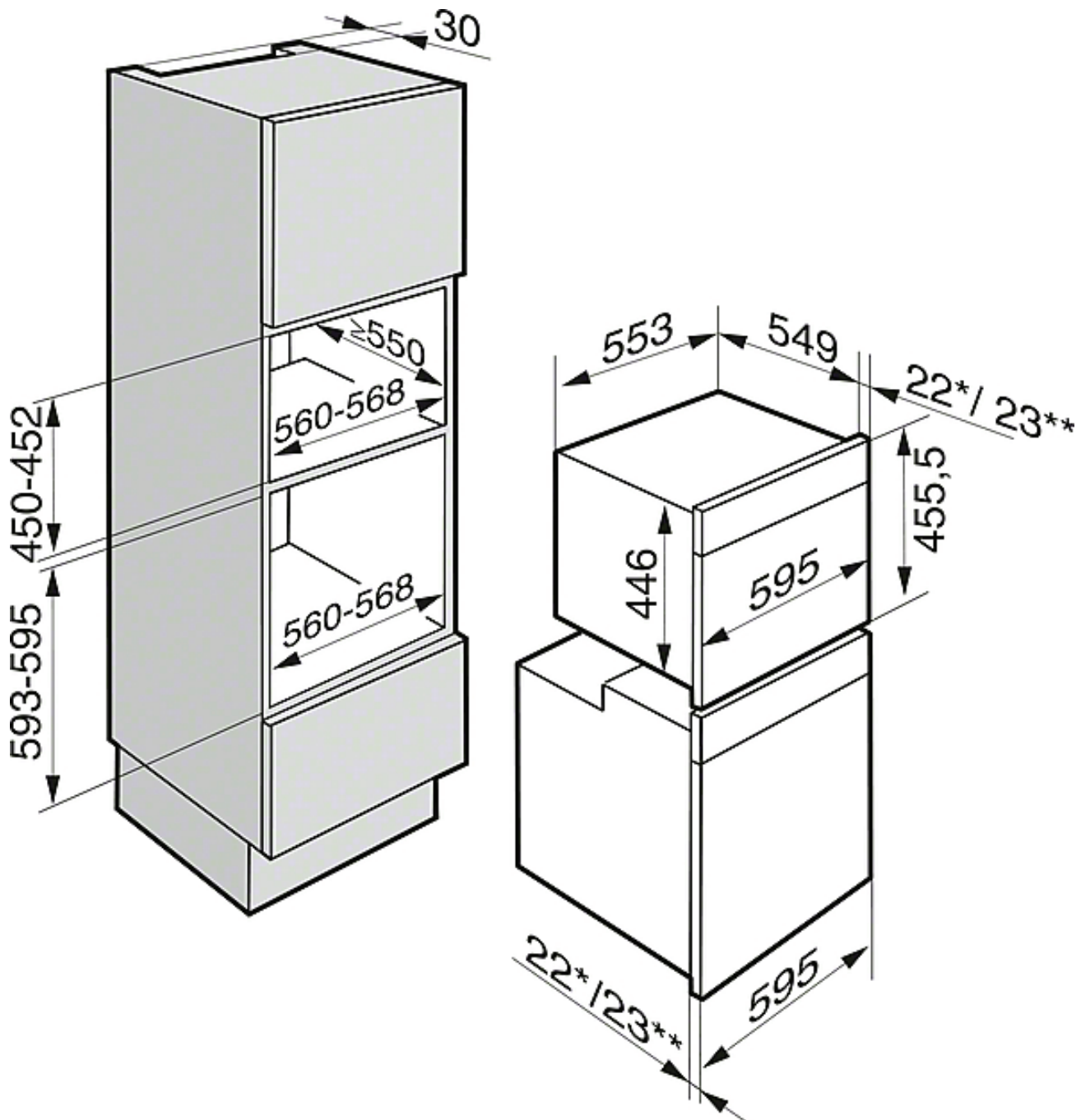

Miele

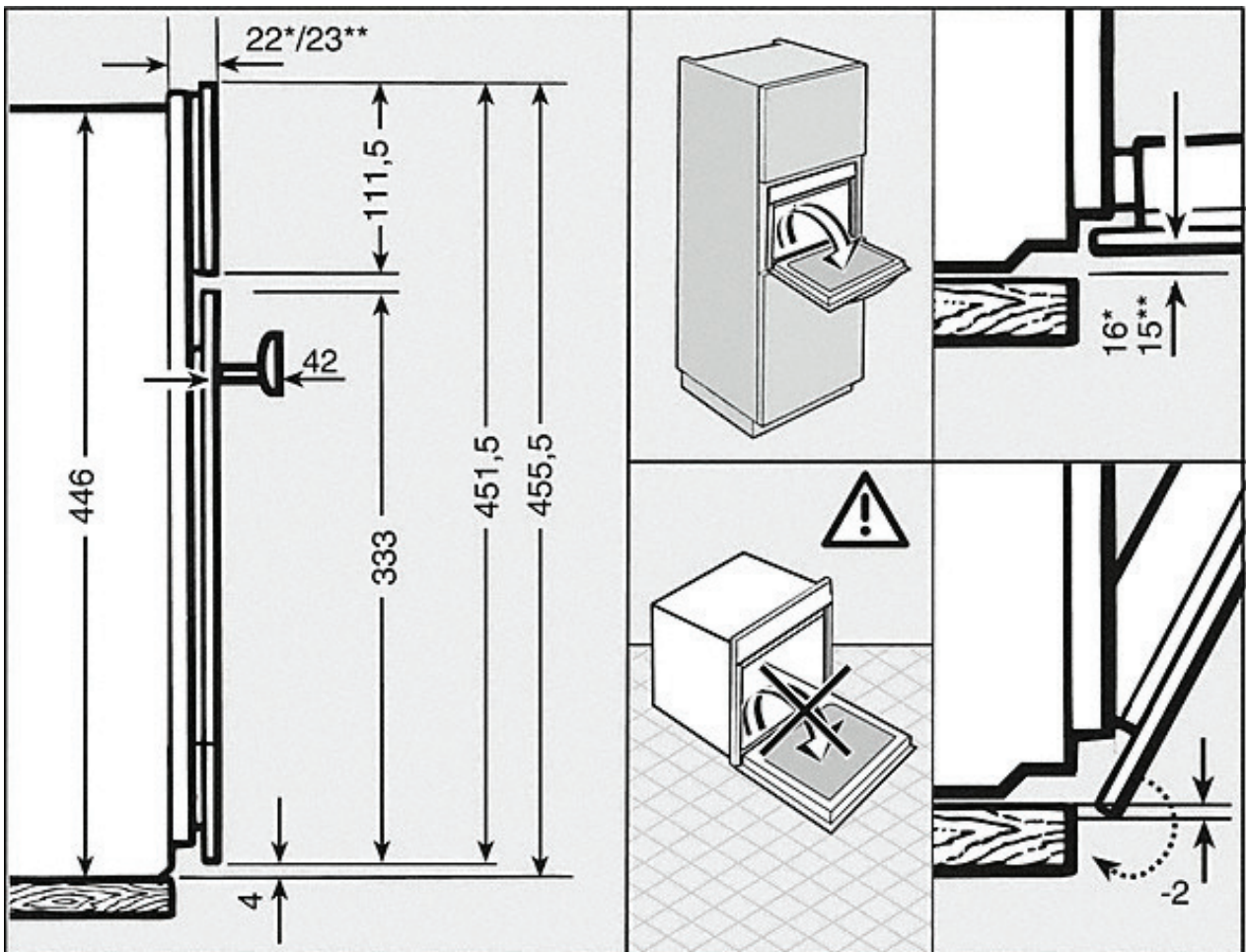
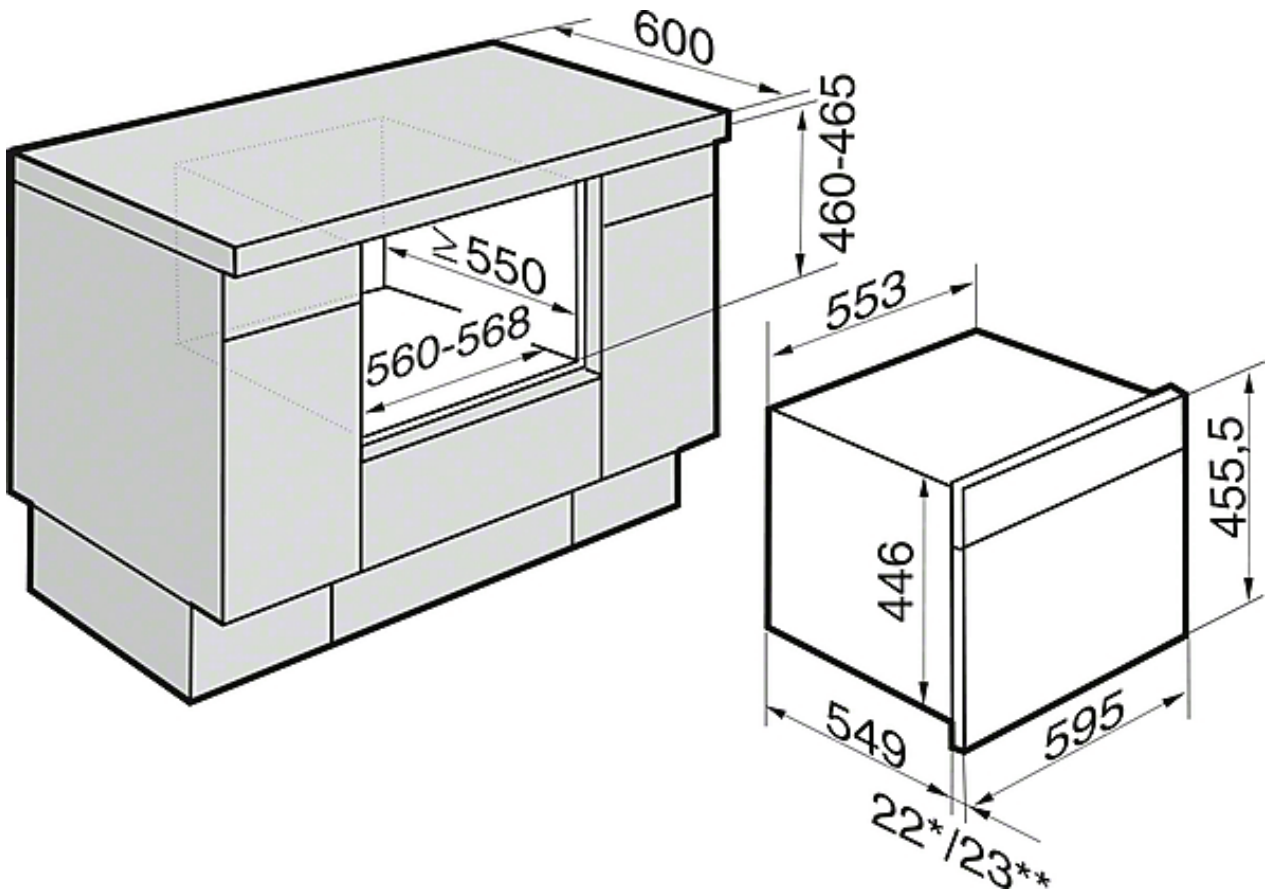

DGC 6805 XL I Plumbed connection (installation drawing)

1. Stopcock (cold water connection) with 3/4" connection thread
2. Water inlet hose, L=2000 mm
3. Drain hose, L=3000 mm
4. The distance between the top of the drain hose and the odour trap must not exceed 500 mm.
5. Attention! The water inlet hose and drain hose must not get trapped behind position (5) when building the appliance in above an oven.

