

Miele

STEAM OVEN WITH PRESSURE

DGD 4635

Steam oven with pressure
the fastest and most powerful steam oven.

- Quickest heating times and shortest cooking times – Power-Steam
- Maximum user and cleaning convenience – fresh water connection
- Exemplary safety thanks to reliable safety systems
- A great feature – telescopic shelf
- Maximum enjoyment through automatic cool-down



SPECIFICATIONS

Niche width in mm	560 - 568
Niche height in mm	380 - 380
Niche depth in mm	555
Appliance width in mm	595
Appliance height in mm	385
Appliance depth in mm	602
Weight in kg	36.1
Total rated load in kW	5,1-5,6
Voltage in V	230-240
Fuse rating in A	16
Number of phases	3

INSTALLATION DRAWING KEY:

DRAWINGS A + B: 1. AB 45-7 - optional accessories

* Appliances with glass front

** Appliances with metal front

DRAWING C: WATER CONNECTION DRAWING

1. Cut-out in the housing unit for feeding the water inlet and outlet hoses through
2. Area for mains connection box 250 x 80 mm, mains connection cable, L=2000 mm
3. Stopcock (cold water connection) with 3/4" connection thread
4. Water inlet hose, L=2000 mm
5. Second separate siphon
6. Do not connect the drain hose here!
7. Drain hose, L=2500 mm
8. The distance between the top of the drain hose and the odour trap must not exceed 500 mm.
9. Attention! The water inlet hose and drain hose must not get trapped behind position (9) when building the appliance in above an oven.

Miele

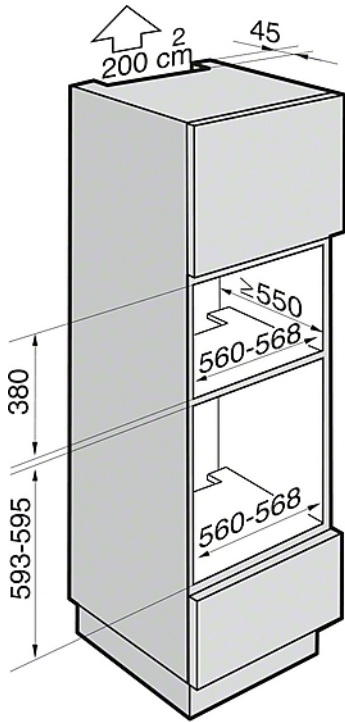

DRAWING A

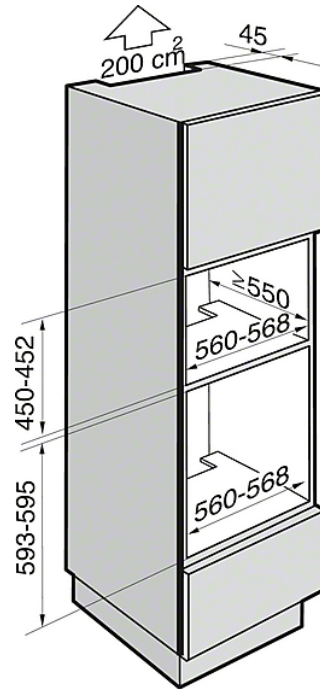
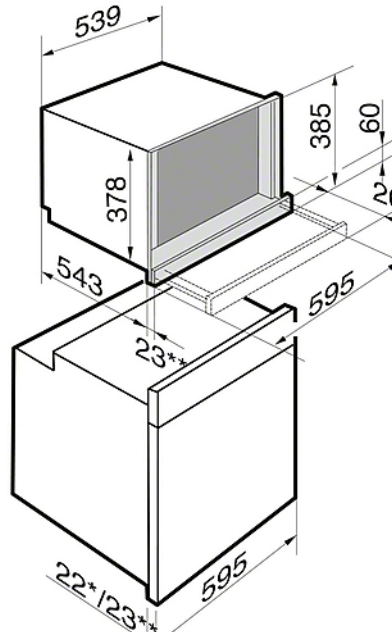

DRAWING B

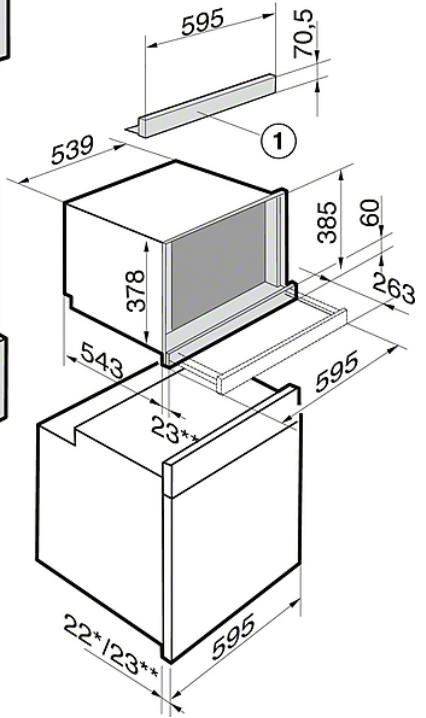

DRAWING C

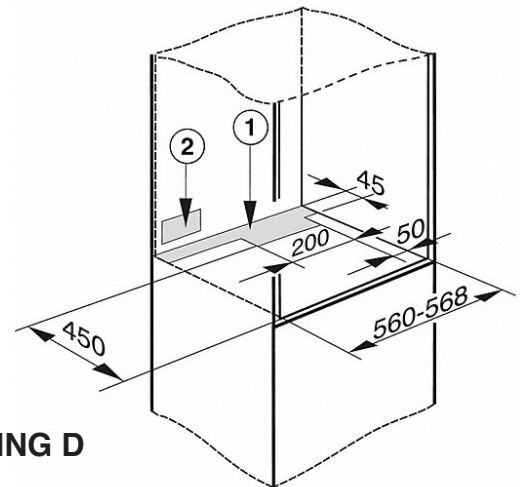
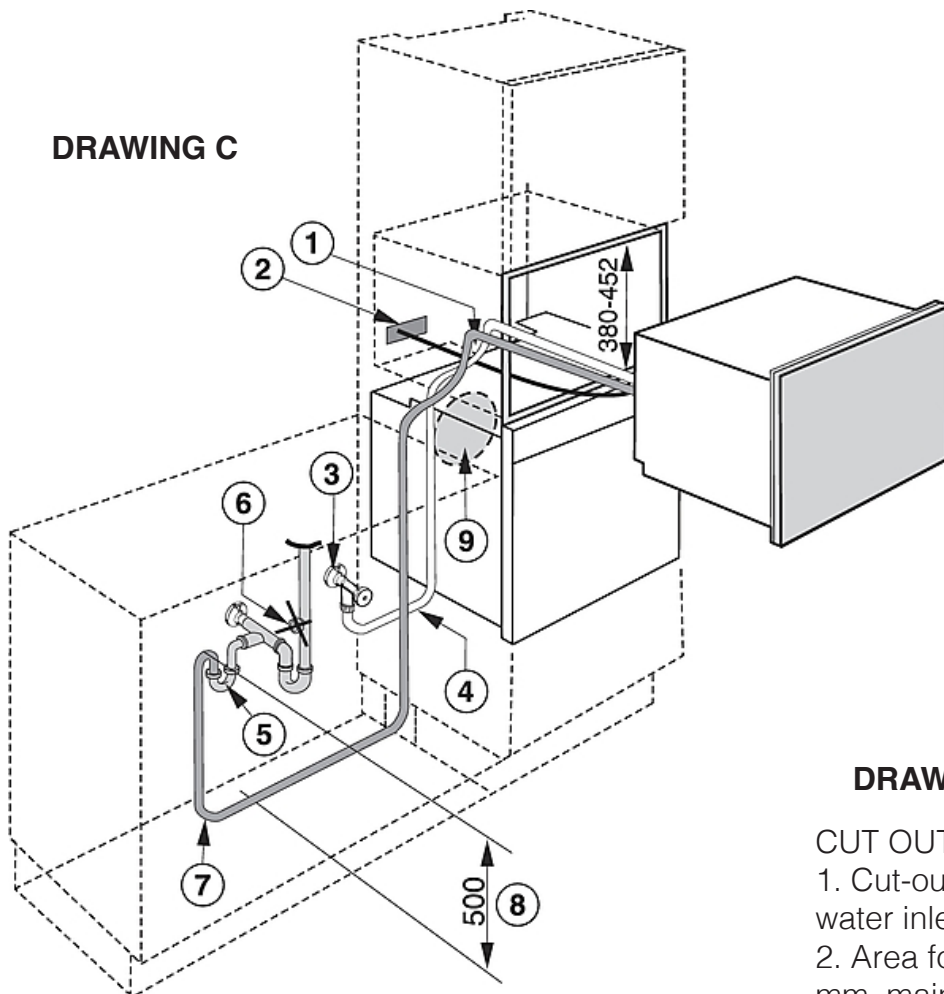

DRAWING D

CUT OUTS DRAWING:

1. Cut-out in the housing unit for feeding the water inlet and outlet hoses through
2. Area for mains connection box 250 x 80 mm, mains connection cable