

LIEBHERR

EGN 9271 & EKB 9471

Quality, Design and Innovation



MONOLITH

kouzina

Kouzina Appliances Ltd
sales@kouzina.co.nz
kouzina.co.nz

Auckland 155 The Strand, Parnell (09) 377 7822
Christchurch 148 Victoria Street, Christchurch Central (03) 365 8338
Queenstown Shop 12, The Landing, Hawthorne Drive (03) 428 2731

LIEBHERR

With its impressive size, clean lines, innovative interior features and whisper-quiet operation, the Monolith was designed to inspire awe and integrate seamlessly into your kitchen motif – today, tomorrow, and for years to come. Thanks to Liebherr's superior energy efficiency as well as intelligent features such as BioFresh technology, Monolith takes advanced food preservation to an entirely new level.

Monolith BioFresh-Plus drawer adds another dimension of climate control to the BioFresh system by allowing you to set temperatures inside the third drawer to as low as -2°C. That's the perfect temperature for preserving the freshness and flavours of seafood. The adjustable InfinityLight LED system casts beautiful and even side lighting, giving a soft, brightening effect upon opening the doors. Our intuitive electronic touch-control panel, InfinitySwipe, features a full-colour 3.5-inch touch & swipe screen that's bright, clean and wonderfully user-friendly. Stainless steel handles and fronts are available as optional accessories.

Possible Side-by-Side combinations

EGN 9271 & EKB 9471

EGN 9271 & EKB 9671

EGN 9171 & EKB 9471



Monolith 137.2 cm

Energy consumption (kWh/y)
Sound rating dB(A) *
Refrigerator capacity litre
BioFresh / BioFresh-Plus comp. litre
Freezer capacity litre
Number of shelves
Number of door racks
Number of FrostSafe drawers
Number of BioFresh / BioFresh-Plus drawers
Electronic control
Door / side walls
Refrigerator temperature range °C **
Freezer temperature range °C
Temperature alarm
Defrost type
Interior light
Door alarm
Internal water dispenser
Water filter
IceMaker
Ice cube output kg/24h
SoftSystem
Door hinges
Product dimensions (H/W/D) cm
Cut out dimensions (H/W/D) cm
Gross / Net weight kg
Voltage V/Hz

* Noise output - according to EN 60704-3

** BioFresh bins, 0°C. BioFresh-Plus bins, -2°C or 0°C.

*** Please contact your Liebherr Authorised Dealer for door reversal.

EGN 9271

Infinity Light	Ice Maker	Soft System	Soft Telescopic
----------------	-----------	-------------	-----------------

EKB 9471

Bio Fresh-Plus	Infinity Light	Soft System	Soft Telescopic
----------------	----------------	-------------	-----------------

39	39
-	425
-	199
325	-
4	4
3	3
3	-
-	2 / 1
InfinitySwipe	InfinitySwipe
Steel	Steel
-	+2°C to +7°C
-14°C to -27°C	-
Visual and audible	Visual and audible
Automatic	Automatic
InfinityLight	InfinityLight
Audible	Audible
-	InfinitySpring
Yes	-
Fixed water connection 20 mm (3/4")	-
1.6	-
Yes	Yes
Left, reversible ***	Right, reversible ***
212.6 / 60.2 / 61	212.6 / 75.4 / 61
213.4 / 61 / min. 63.5	213.4 / 76.2 / min. 63.5
168 / 156	192 / 178
220-240 / 50	220-240 / 50

LIEBHERR



Soft System

SoftSystem: Monolith's doors close automatically and gently thanks to our SoftSystem technology, which eliminates slamming even when shelves are fully loaded. Depending on the size of the Monolith unit, door hinges can hold up to 35.8 kg.

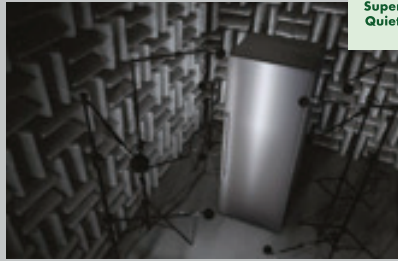

Super Quiet

SuperQuiet: Noise levels are kept to a minimum thanks to virtually silent, speed-controlled, and sound absorbing compressors. Alongside a low noise cooling circuit, these features ensure exact performance, energy efficiency, and SuperQuiet operation.



Bio Fresh-Plus

BioFresh-Plus: BioFresh technology offers you the perfect climate for superior, long-lasting food freshness. In addition to two BioFresh drawers, the third drawer in the Monolith fridge can be set to BioFresh-Plus by lowering temperatures down to -2°C, ideal for storing fresh fish and seafood.



Infinity Spring

InfinitySpring: The seamlessly integrated, flush-mounted InfinitySpring internal water dispenser is there when you need it, and also virtually invisible when you don't. This dispenser can accommodate water pitchers of any size. In addition our filtration system eliminates harmful contaminants, resulting in crisp, clear, fresh tasting water.



Infinity Light

InfinityLight: Seamlessly integrated LED side-wall lighting in the Monolith casts a beautiful and even glow that can be adjusted to your liking. It gives a soft, brightening effect upon opening the appliance doors and comes with a pleasing night dimming feature. InfinityLight adds drama and flair while emitting less heat to preserve food quality.



Infinity Swipe

InfinitySwipe: The Monolith's intuitive electronic touch-control panel features a full-colour 3.5-inch touch and swipe screen that's bright, clean, and wonderfully user-friendly. You'll barely have to lift a finger to control every function.

Optional Accessories

Stainless steel front

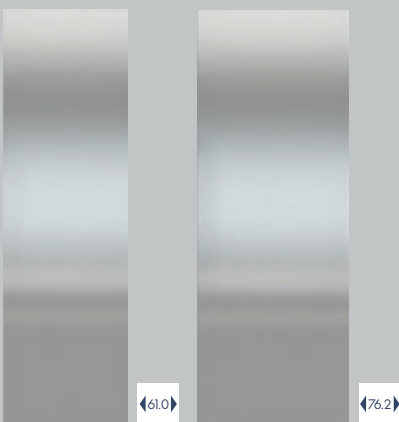

Stainless steel front 61.0 cm
(Part no. 990188300)

Stainless steel front 76.2 cm
(Part no. 990187200)

Handle variants



Flat brushed aluminium handle
(Part no. 990146100)

Round stainless steel handle
(Part no. 990148900)

Square brushed aluminium handle
(Part no. 990149200)

Stainless steel toe kick



Stainless steel toe kick
Base - trim / 61.0 cm (Part no. 990149300)

Stainless steel toe kick
Base - trim / 76.2 cm (Part no. 990153000)

Stainless steel toe kick
Base - trim / 137.2cm (Part no. 990178700)

Side-by-Side kit

Monolith's Side-by-Side kit (Part no. 990142800) includes a side wall heater to prevent condensation, metal brackets with screws, and a finishing strip to fill the gap between the appliances.

Product Dimensions

61.0 cm appliance

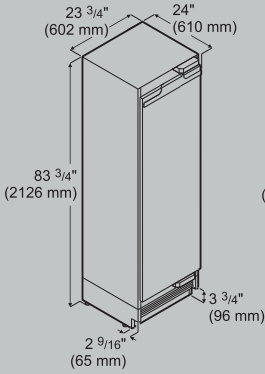

76.2 cm appliance

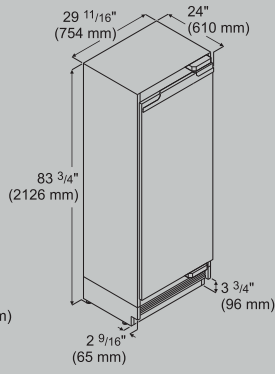

IMPORTANT!
Minimum height dimensions indicated in diagrams include height of the adjustable feet when fully extended.

All Monolith ventilation takes place through the toe kick area. Door fronts must be a minimum of 4" (102 mm) above the floor.

When fitted in the recess, the appliance must be raised (by turning the adjustable feet) so that the appliance top comes into contact with the anti-tipping bracket. Maximum height increase of adjustable feet is 1" (26 mm). This results in a toe kick height of 4" (102 mm).

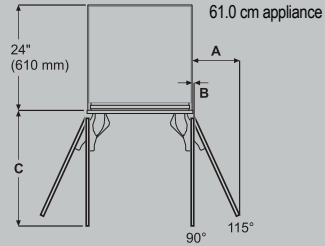

Inset
A = 10 3/4" (273 mm)
B = 1/2" (12.5 mm)
C = 25 7/8" (658 mm)

Frameless
A = 11" (279 mm)
B = 1/2" (12.5 mm)
C = 26 3/8" (670 mm)

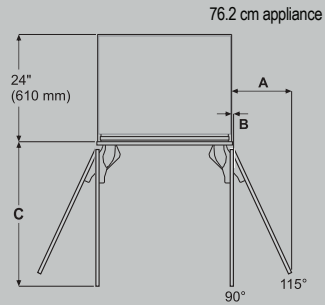

Inset
A = 13 1/4" (337 mm)
B = 1/2" (12.5 mm)
C = 31 7/8" (810 mm)

Frameless
A = 13 1/2" (343 mm)
B = 1/2" (12.5 mm)
C = 32 3/8" (822 mm)

Dimension A = without mounted door handle

Cut Out Dimensions

Continuous toe kick

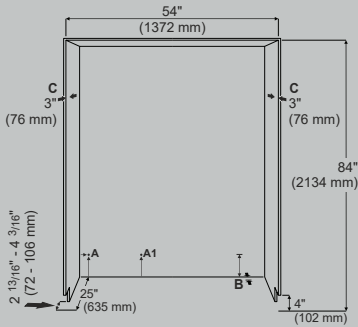

Individual toe kick

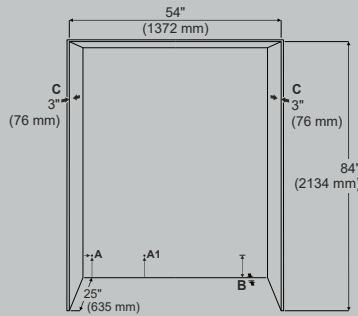

A: This is where the power cord exits the appliance rear, 3/4" (19 mm) from the left and 5" (127 mm) from the floor. Free length of the power cord is 98" (2.5 m). Power outlet is recommended to be placed outside of the appliance opening. A power supply of 220-240V with circuit grounded and protected by a circuit breaker is required. Socket must be properly earthed and protected by a fuse of 15A or 20A.

B: The appliance has a recess here for cable and waterline laying, 1" (25 mm) in depth and 5 1/2" (140 mm) in height over the whole width of the appliance. With the water filter installed, the pressure must be 40-90 psi. Without the water filter installed, the acceptable pressure is 22-87 psi. A shut-off valve must be installed between the water line and the main water supply, and must be easily accessible so that water supply can be stopped immediately if necessary.

C: This surface will be visible when the appliance door is open hence designed finish is required.

Door Panel Dimensions



61.0 cm recess

Inset installation style
H = 79 7/8" (2029 mm)
W = 23 3/4" (603 mm)

Frameless installation style
H = 80" (2032 mm)
Add overlapping dimension to the panel on the top.
W = 24" (610 mm)
Add overlapping dimension to the panel on both sides.

Maximum panel weight = 52 lbs. (24 kg)



76.2 cm recess

Inset installation style
H = 79 7/8" (2029 mm)
W = 29 3/4" (756 mm)

Frameless installation style
H = 80" (2032 mm)
Add overlapping dimension to the panel on the top.
W = 30" (762 mm)
Add overlapping dimension to the panel on both sides.

Maximum panel weight = 79 lbs. (36 kg)