

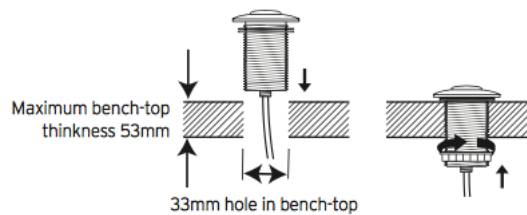

EVOLUTION 100 FOOD WASTE DISPOSER EVOLUTION 100

Featuring two-stage grinding combined with SoundSeal™ Plus technology, the Evolution 100 is more powerful and quieter than our standard range. It virtually grinds any food waste, including difficult items such as bones and potato peel.



SPECIFICATIONS

Features:

- SoundSeal Plus™ Technology delivers ultra-quiet performance. 40% quieter than standard models.
- MultiGrind Plus™ 2 Stage Stainless Grinding System with Auto Reverse Action
- Large Capacity (1005ml) Stainless Steel Grinding Chamber
- QuickLock™ Sink Mount for easy installation
- Built-in Air Switch (33mm hole for button)
- Stainless Steel Strainer Basket
- 0.75HP High-torque Dura Drive™ Heavy Duty Induction Motor
- 5 Year Warranty

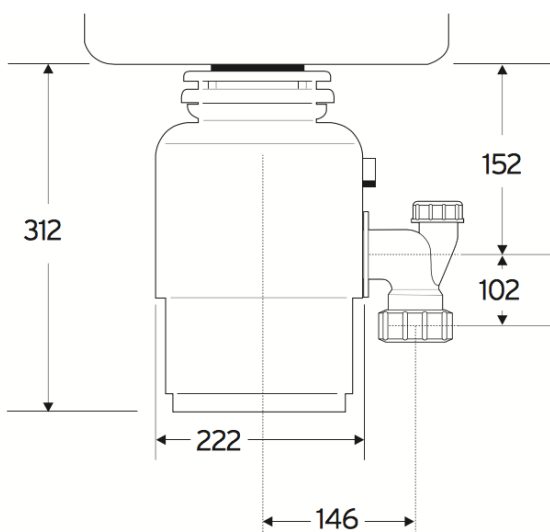

Type of Feed	Continuous		
On/Off	Control Wall Switch or Built-In Air Switch		
Power Supply	Single Phase		
Reversing	Auto-Reverse Grind System		
Time Rating	Intermittent		
Lubrication	Permanently Lubricated Upper & Lower Bearings		
Shipping Weight	8.8 kg (Approx.)		
Unit Finish	Black Enamel Grey TEN-1706		
Overall Height	312 mm		
Grind Technology	2-Stage Grind Technology		
Volts/Hz	HP	RPM	
220-240V, 50 Hz	.75	1425	
Sound Technology	Anti-Vibration Mounting Technology and Tailpipe Quiet Sink Baffle Multi-Layer Sound Insulation		
Plug	Stainless Steel Strainer Basket and Plug		
Grind Chamber Capacity	1005 ml		
Motor Protection	Manual Reset Overload		
Average Water Usage	Approximately 4.0 L per Person per Day		
Average Electrical Usage	3-4 KWH per Annum		
Drain Connection	1-1/2" (3.81 cm) Anti-Vibration (Hose Clamp)		
Dishwasher Connection	Yes		