

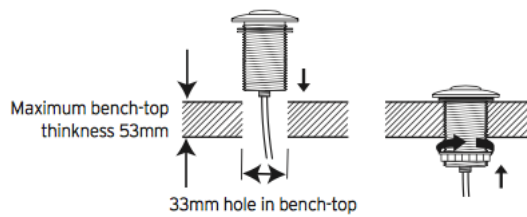

## EVOLUTION 200 FOOD WASTE DISPOSER

### EVOLUTION 200

The Evolution 200 with its three-stage grind technology & Sound-Seal™ Plus, makes it our most powerful & quietest model. Don't worry about what you can and can't grind... the Evolution 200 grinds all food waste



## SPECIFICATIONS

### Features:

- SoundSeal Plus™ technology delivers ultra-quiet performance. 60% Quieter than standard models.
- MultiGrind Plus™ 3 Stage Stainless Grinding System with Auto Reverse Action
- Largest Capacity (1180ml) Stainless Steel Grinding Chamber
- Micro Processor that detects when the motor is under extra load and delivers more power to boost the grinding capability
- Built-in Air Switch (33mm required for the button)
- QuickLock™ Sink Mount 'twist-on, twist-off' sink mount makes installation fast and easy
- Stainless Steel Strainer Basket & Plug
- 0.75H High-torque Dura-Drive™ Duty Induction motor

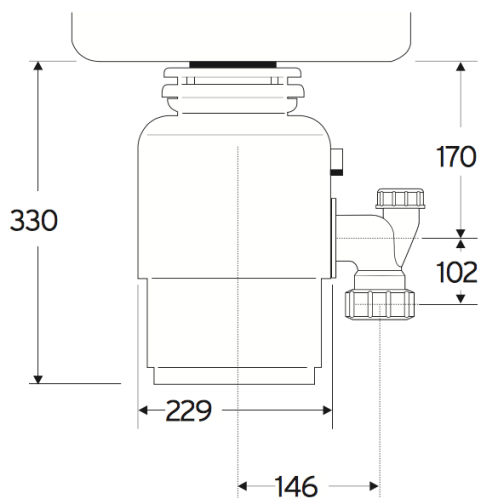

<b>Type of Feed</b>	Continuous		
<b>On/Off</b>	Control Wall Switch or Built-In Air Switch		
<b>Power Supply</b>	Single Phase		
<b>Reversing</b>	Auto-Reverse Grind System		
<b>Time Rating</b>	Intermittent		
<b>Lubrication</b>	Permanently Lubricated Upper & Lower Bearings		
<b>Shipping Weight</b>	11.6 kg (Approx.)		
<b>Unit Finish</b>	Stainless Steel Light Grey TEN-1706		
<b>Overall Height</b>	344 mm		
<b>Grind Technology</b>	3-Stage Grind Technology Power Booster Circuit with Microprocessor		
<b>Sound Technology</b>	Anti-Vibration Mounting Technology and Tailpipe Quiet Sink Baffle Multi-Layer Sound Insulation		
<b>Plug</b>	Stainless Steel Strainer Basket and Plug		
<b>Grind Chamber Capacity</b>	1180 ml		
<b>Motor Protection</b>	Manual Reset Overload		
<b>Average Water Usage</b>	Approximately 4.0 L per Person per Day		
<b>Average Electrical Usage</b>	3-4 KWH per Annum		
<b>Drain Connection</b>	1-1/2" (3.81 cm) Anti-Vibration (Hose Clamp)		
<b>Dishwasher Connection</b>	Yes		
<b>Volts/Hz</b>	220-240V, 50 Hz	<b>HP</b>	<b>RPM</b>
		.75	1425