

FISHER & PAYKEL

SPECIFICATION GUIDE

FRONT LOADER WASHING MACHINE, 10KG SERIES 9



OVERVIEW

With a stylish, new graphite finish, this 10kg Front Loader Washing Machine pairs perfectly with its matching Heat Pump Dryer for a clean, considered laundry. Designed to handle large loads, it has advanced wash functions and auto-dosing technology. Beautiful to use, this front loader features 14 fabric care cycles including Steam Refresh which is perfect for quickly reducing odours and dewrinkling clothes.

MODELS

Front Loader Washing Machine, 10kg, Steam Care
WH1060SG1

SERIES

Series 9
Front Loader

FEATURES

- ① New Graphite finish, pairs perfectly with the Heat Pump Dryer in Graphite
- ② Large 10kg capacity, with 4.5 Star Energy and Water Rating
- ③ 14 cycles including Steam Refresh, Quick 15 and Wool
- ④ Steam Refresh dewrinkles, deodorises, and refreshes clothes in quick 20-minute cycle
- ⑤ Auto Dose dispenses the right amount of detergent and fabric softener for each wash
- ⑥ Sanitise cycle eliminates 99.9% of common bacteria
- ⑦ Save time, minimise noise and reduce water usage with Optimise Wash options
- ⑧ SmartDrive™ technology ensures a quiet and reliable wash
- ⑨ Fast and even mixing of detergent with Vortex Wash
- ⑩ Add or remove items during the wash cycle with Add a Garment
- ⑪ WiFi enabled, for ongoing improvements with software updates

ACCESSORIES

- ① 1x hose set

FISHER & PAYKEL

SPECIFICATION GUIDE

FRONT LOADER WASHING MACHINE, 10KG SERIES 9

SPECIFICATIONS

Model No.	WH1060SG1
Dimensions	H 850mm W 600mm D 675mm
Weight	82kg
Electrical	
Supply	220 - 240V, 50Hz
Service	10-amp circuit
Outlet	3-prong grounding-type
Plumbing	
Supply	Hose set provided
Pressure	Max. 1MPa (150psi) Min. 50KPa (7psi), Min. 6 litres/min

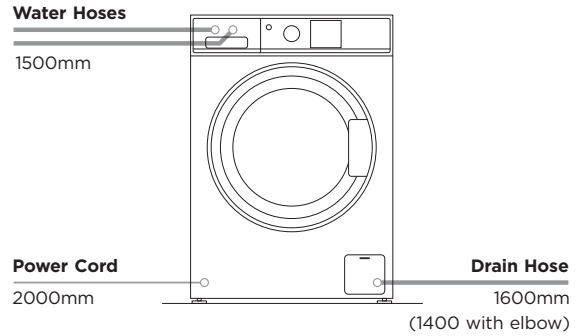

PRODUCT DIMENSIONS

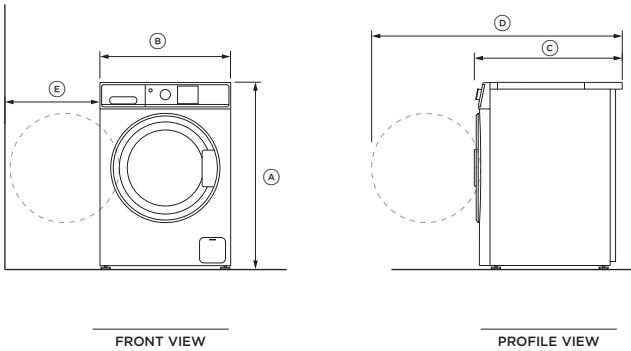

CAVITY DIMENSIONS: STANDARD INSTALLATION

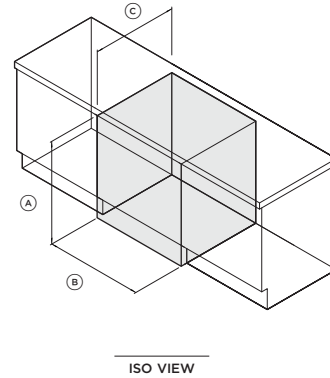

	mm
(A) Overall height*	min 845 max 860
(B) Overall width	600
(C) Overall depth**	675
(D) Depth with the door open	1080
(E) Min. door clearance to adj. wall	355

* Includes adjustable mounted feet and the range of movement

** Includes dial and door when closed

	mm
(A) Minimum height*	865
(B) Minimum width	640
(C) Minimum overall cavity depth	
• Flush with front panel of the product	655
• In cupboard	715
Minimum gap clearance to adjacent product or cabinetry**	20

* Depends on feet adjustment

** Applies to sides, top and rear