

FN 28262 edt/cs

Freestanding freezer

with Frost free and lever handle for convenient side-by-side combination.



- Optimum and maintenance-free LED lighting in compartment
- High efficiency and top-class freshness
- No icing up of food and no need to defrost thanks to Frost free
- Easy and effortless opening of refrigerators thanks to EasyOpen

Appliance category	
Freezer	•
Construction type	
Freestanding appliance	•
Door hinge	Left
Side-by-side enabled	•
Design	
Casing colour	Stainless steel look
Front colour	Stainless steel/CleanSteel
Freezer compartment lighting	LED
User convenience	
NoFrost	•
VarioRoom	•
Concealed door opener	EasyOpen lever handle
Controls	
Operating concept	TouchControl
No. of temperature zones	1
Fridge/Fridge section	
Height-adjustable tempered glass shelves	•
Freezer/Freezer section	
Number of freezer drawers/baskets	Qty 8
Safety	
Acoustic door alarm	•
Acoustic temperature alarm, freezer section	•
Optical door alarm	•
Optical temperature alarm	•
Technical data	
Appliance width in mm	600
Appliance height in mm	1,852
Appliance depth in mm	630
Weight in kg	76.10
Climate class	SN-T
4* freezer compartment in l	253
Storage time in case of fault	20
Freezer capacity in kg/24 h	20.0
Current consumption (mA)	1,300
Voltage in V	220-240
Fuse rating in A	10
Length of supply lead in m	2.0
Standard accessories	
Ice packs	•
Ice cube tray	•

FN 28262 edt/cs

Freestanding freezer

with Frost free and lever handle for convenient side-by-side combination.

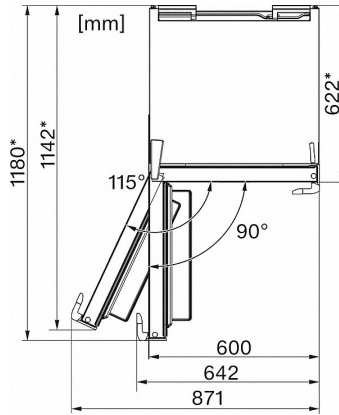

FN28262, FN28202, Draufsicht, (Skizze) (*Fußnote)

*To ensure that energy consumption as stated is achieved, machines should be used together with the enclosed spacer brackets. This increases the total depth of the unit by approx. 3.5 cm. Machines are still fully functional when operated without these brackets but have a slightly higher energy consumption.

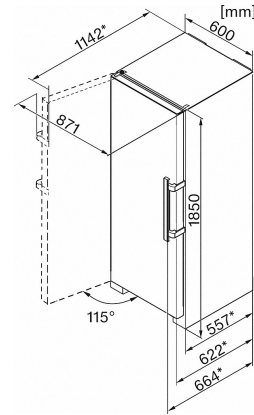

FN28262, FN28202, (sketch) (*footnote)

*To ensure that energy consumption as stated is achieved, machines should be used together with the enclosed spacer brackets. This increases the total depth of the unit by approx. 3.5 cm. Machines are still fully functional when operated without these brackets but have a slightly higher energy consumption.