



#### Color Variants

CI262115

Stainless steel frame

Width 60 cm

CI262115

Flex induction cooktop 200 series

Stainless steel frame

Width 60 cm

Sturdy stainless steel frame  
Flex function for combining the rectangular cooking areas  
Free positioning of cookware inside combined cooking areas with automatic extension up to 30 cm width  
Cooking sensor function for temperature control in pots  
Professional cooking function for splitting the cooktop into 3 predefined heat areas  
Frying sensor function for temperature control in pans  
Twist-Pad control with removable magnetic knob  
Easy control of all functions with bicoloured display

#### Cooking zones

2 flex induction cooking areas 19x22,5 cm (2200 W, with booster 3700 W), linked together 38x22,5 cm (3300 W, with booster 3700 W), with automatic extension up to 30x30 cm (3300 W, with booster 3700 W).

#### Handling

Twist-Pad control with removable magnetic knob.  
User friendly control with bicoloured display (white / orange).  
Cooking zone and cooking area marking.  
Electronic power control in 17 cooking power levels.

#### Features

Flex function for rectangular cooking areas.  
Professional cooking function.  
Cooking sensor function (in use with cooking sensor CA 060 300).  
Frying sensor function.  
Booster function for pots.  
Booster function for pans.  
Keep warm function.  
Stopwatch.  
Cooking timer for up to 99 minutes.  
Short-term timer.  
Options menu.  
Power management.  
Cooktop-based ventilation control (with suitable hood).  
Home network integration for digital services (Home Connect) wireless via WiFi.  
The use of the Home Connect functionality depends on the Home Connect services, which are not available in every country. For further information please check: [home-connect.com](http://home-connect.com).

#### Safety

Main switch.  
Operation indicator.  
Pot detection.  
Digital 2-step  
Child lock.  
Safety shut-off.

#### Planning notes

Operates with magnetic (induction) iron pots and pans only. For an optimal heat distribution, the use of sandwich bottom cookware is recommended.  
The wok pan WP 400 001 cannot be used with this appliance.  
Appliance must be fixed from underneath.  
Appliance weight: approx. 16. kg

#### Connection

Total connected load 7.4 KW.

#### Characteristics

Product name/family

Cooking zone ceramic

Construction type

Built-in

Energy input

Electric

Total number of positions that can be used at the same time

4

Type of control setting devices

Required niche size for installation

(HxWxD)

55 x 560-560 x 490-490

Width of the appliance

590

Dimensions

55 x 590 x 520

Dimensions of the packed product

(HxWxD)

126 x 753 x 608

Net weight

15.9

Gross weight

17.1

Residual heat indicator

Separate

Location of control panel

Hob front

Type of external control possibility

Basic surface material

Ceramic

Color of surface

Black, Stainless steel

Color of frame

Stainless steel

Approval certificates

AENOR, CE

Length electrical supply cord

150

EAN code

4242006287795

Electrical connection rating

7400

Gas connection rating

Fuse protection

Voltage

220-240

Frequency

50-60

#### Consumption and connection features

2022-02-15

Page 1

Connecting cable 1.5 m without plug.  
Power consumption standby/display off 0.5 W.  
Power consumption standby/network 2.0 W.  
Please check the user manual for how to switch off the WiFi module.

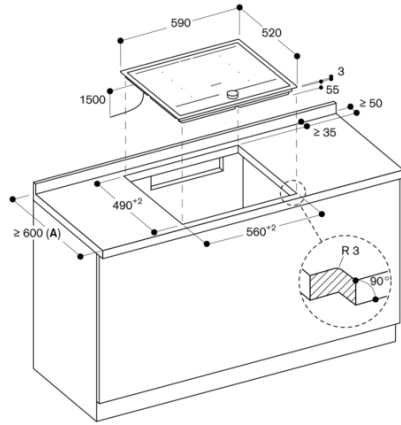

A: Please check the installation manual if the worktop depth is less than 600 mm.  
measurements in mm