



#### Color Variants

CI292102

Frameless

Width 90 cm

CI292102  
Flex induction cooktop 200 series  
Frameless  
Width 90 cm

Frameless for flush mounting  
Flex function for combining the rectangular cooking areas  
Free positioning of cookware inside combined cooking areas  
Professional cooking function for splitting the cooktop into 3 predefined heat areas  
Cooking sensor function for temperature control in pots  
Frying sensor function for temperature control in pans  
Large cooking zone for pots up to  $\varnothing$  32 cm  
Twist-Pad control with removable magnetic knob  
Easy control of all functions with bicoloured display

#### Cooking zones

2 flex induction cooking areas 20x23 cm (2200 W, with booster 3700 W), linked together 40x23 cm (3300 W, with booster 3700 W).  
1 induction cooking zone  $\varnothing$  21 cm (2200 W, with booster 3700 W), automatically switches to  $\varnothing$  26 cm (2600 W, with booster 3700 W) and to  $\varnothing$  32 cm (3300 W, with booster 3700 W).

#### Handling

Twist-Pad control with removable magnetic knob.  
User friendly control with bicoloured display (white / orange).  
Cooking zone and cooking area marking.  
Electronic power control in 17 output levels.

#### Features

Flex function for rectangular cooking areas.  
Professional cooking function.  
Cooking sensor function (in use with cooking sensor CA 060 300).  
Frying sensor function.  
Booster function for pots.  
Booster function for pans.  
Keep warm function.  
Stopwatch.  
Cooking timer for up to 99 minutes.  
Short-term timer.  
Options menu.  
Power management.  
Cooktop-based ventilation control (with suitable hood).  
Home network integration for digital services (Home Connect) wireless via WiFi.  
The use of the Home Connect functionality depends on the Home Connect services, which are not available in every country. For further information please check: [home-connect.com](http://home-connect.com).

#### Safety

Main switch.  
Operation indicator.  
Pot detection.  
Digital 2-step  
Child lock.  
Safety shut-off.

#### Planning notes

Operates with magnetic (induction) iron pots and pans only. For an optimal heat distribution, the use of sandwich bottom cookware is recommended.  
Appliance must be fixed from underneath.  
Appliance weight: approx. 27. kg

#### Characteristics

Product name/family  
Cooking zone ceramic  
Construction type  
Built-in  
Energy input  
Electric  
Total number of positions that can be used at the same time  
5  
Type of control setting devices  
Required niche size for installation (HxWxD)  
Width of the appliance  
908  
Dimensions  
56 x 908 x 520  
Dimensions of the packed product (HxWxD)  
126 x 1073 x 608  
Net weight  
27.453  
Gross weight  
29.2  
Residual heat indicator  
Separate  
Location of control panel  
Hob front  
Type of external control possibility  
Basic surface material  
Ceramic  
Color of surface  
Black  
Color of frame  
Approval certificates  
AENOR, CE  
Length electrical supply cord  
150  
EAN code  
4242006293192  
Electrical connection rating  
11100  
Gas connection rating  
Fuse protection  
Voltage  
220-240  
Frequency  
50-60

#### Consumption and connection features

2022-01-22  
Page 1

#### Connection

Total connected load 11.1 KW.  
Connecting cable 1.5 m without plug.

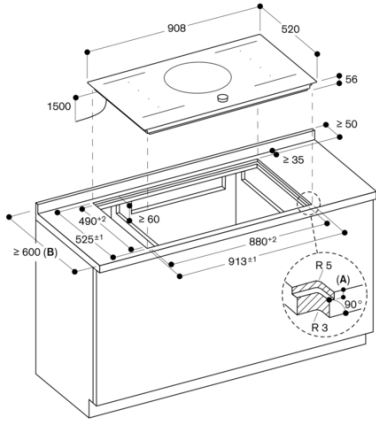

A:  $6.5^{+0.5}$   
 B: Please check the installation manual if the worktop depth is less than 600 mm.  
 measurements in mm

Cross-section

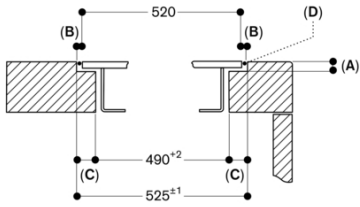

A:  $6.5^{+0.5}$   
 B: 2.5  
 C: 17.5  
 D: Fill with silicone  
 measurements in mm

View from above

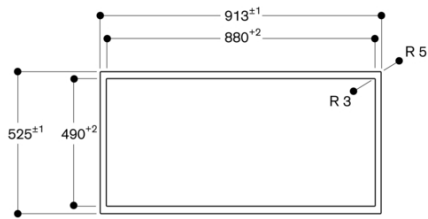

measurements in mm

Longitudinal section

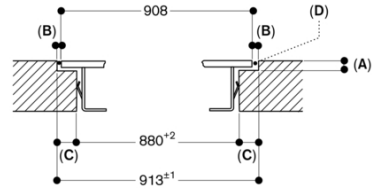

A:  $6.5^{+0.5}$   
 B: 2.5  
 C: 16.5  
 D: Fill with silicone

measurements in mm