



DF480100

Dishwasher 400 series

Fully integrated

Height 81.5 cm



Optimal protection for sensitive glassware by low temperature drying with zeolite, elaborated basket design and intelligent water softening
8 programs with aqua sensor and 4 options, such as Power for cleaning and drying dishes in 57 minutes and Intensive for particularly thorough cleaning in the lower basket
Flexible basket system with smooth running rails on all levels and cushioned closing of the upper and lower basket
Perfectly illuminated interior
Push-to-open function for perfect integration into handleless furniture fronts
Remaining time projection onto the kitchen floor
Very quiet: 42 dB

Capacity

TFT display indicating remaining or end time, refill for salt and rinsing agent, inflow of water.
Touch key operation.
Flexible cycle time reduction, even during an active cycle.
Personalisation function for storing individual combinations of programs.
Temporary noise reduction (only available with active Home Connect functionality).
Information key with use indicators.
Time delay up to 24 hours.
Visual and acoustic end of programme indicator.
Remaining time projection.

Technical Information

Perfectly illuminated interior.
Glass protection with zeolite.
Aqua sensor. Which works with the Aqua stop for detection of leak in the water system
Load sensor.
Automatic detergent function.
Regeneration electronics.
Heat exchanger.
Continuous flow heater.
Triple filter system.
Soft lock.
Aqua stop water safety system.
An electronically controlled water protection system to prevent any water damage
Home network integration for digital services (Home Connect) wireless via WiFi.
The use of the Home Connect functionality depends on the Home Connect services, which are not available in every country. For further information please check: home-connect.com.

Programs

6 programmes:
Auto 35 °C - 45 °C. Auto 45 °C - 65 °C.
Auto 65 °C - 75 °C. Eco 50 °C. Quick wash 45 °C (35 min.). Personalisation function (default setting: Pre-rinse).
4 options:
Intensive. Power. Half Load. Hygiene. Machine Care.

Features

Flexible basket system with smooth running rails on all levels and cushioned closing of the upper and lower basket.
Upper basket:

Characteristics

| | |
|--|--|
| Energy Efficiency Class (Regulation (EU) 2017/1369) | C |
| Energy Consumption for 100 cycles Eco Programme (EU 2017/1369) | 73 |
| Maximum number of place settings (EU 2017/1369) | 12 |
| The water consumption of the eco programme in liters per cycle (EU 2017/1369) | 9.5 |
| Programme duration (EU 2017/1369) | 3:55 |
| Airborne acoustical noise emissions (EU 2017/1369) | 42 |
| Airborne acoustical noise emission class (EU 2017/1369) | B |
| Built-in / Free-standing | Built-in |
| Height of removable worktop | 0 |
| Dimensions of the product (HxWxD) | 815 x 598 x 550 |
| Min. required niche size for installation (HxWxD) | 815-875 x 600 x 550 |
| Depth with open door 90 degree | 1150 |
| Adjustable feet | Yes - all from front |
| Maximum adjustability feet | 60 |
| Adjustable plinth | |
| Net weight | 52.1 |
| Gross weight | 54.0 |
| Connection Rating | 2400 |
| Fuse protection | 10 |
| Voltage | 220-240 |
| Frequency | 50; 60 |
| Length electrical supply cord | 175 |
| Plug type | Gardy plug w/ earthing |
| Length inlet hose | 165 |
| Length outlet hose | 190 |
| EAN code | 4242006297053 |
| Installation typology | Full-integrated |
| Included accessories | 1 x baking tray spray head, 1 x GN container insert, 1 x holder for long-stemmed glasses, 1 x stainless steel trim kit |

Consumption and connection features

2022-11-30
Page 1

Lower basket:

8 folding spines. 2 folding racks for optimal protection of glass. Dividable glass support.
Cutlery basket.
Maximum dish sizes (upper/lower basket)
27/25, 24.5/27.5 or 22/31 cm respectively.
12 place setting capacity.
Maximum glass loading capacity 23 wine glasses.

Consumption Rates

3 Star Energy rating, 5.5 Star Water rating WELS
9.8 litres water consumption per wash in accordance with AS/NZS 6400 and 305 kWh energy consumption per year, with Cold water connection using the Eco 50 °C program seven times per week. When tested in accordance with AS/NZS 2007.2. Actual energy use and running costs will depend on how you use the appliance.
Noise level 42 dB (re 1 pW).
Height-adjustable feet by a total of 120mm

Performance

Appliance plinth recess 100 mm (see drawing).
To display the remaining time projection, a minimum plinth protrusion is required (40 mm + thickness of the furniture front).
The maximum plinth height must be reduced by 30 mm to provide an optimal display of the remaining time projection.
Rear feet adjustable at front.
Door weight up to 8.5 kg.
Door panel dimension dependent on plinth height of kitchen furniture.
Installation and usage also with furniture handle possible. The push-to-open function remains active.

Connection

Total connected load 2000-2400 W.
Connecting cable pluggable.
Water connection with 3/4 " screw joint. Connection to hot or cold water possible.
Power consumption standby/network 2.0 W.
Power consumption left-on-mode 0.5 W.
Power consumption off-mode 0.5 W.
Time auto-standby/network 2 min.
Left-on-mode duration 0 min.
Please check the user manual for how to switch off the WiFi module.

81.5 cm high dishwasher

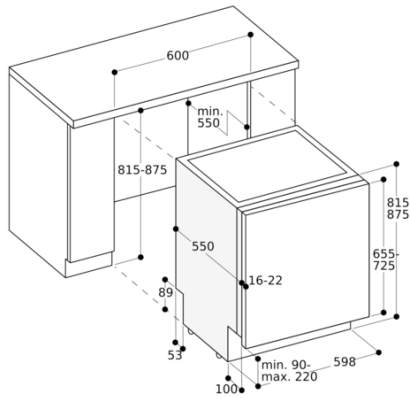

Connection dimensions for a 60 cm wide dishwasher

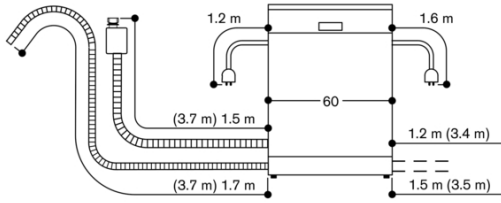

() values with extension kit