

Miele



CLEAN STEEL SPEED OVEN W.600

H 6400 BM

Speed oven with automatic programmes and combination modes for perfect results. 8 functions including 1000 W microwave and 43 l capacity and 3 rack levels. CleanSteel finish.

- TFT text display with rotary selector – DirectControl
- Easy clean – Cook compartment has PerfectClean & linen structure
- Quick cooking – combined microwave modes
- The simple way to perfect results – Automatic programmes
- Fresh popcorn at your fingertips thanks to the Popcorn button

SPECIFICATIONS

Dimensions:

44.8-45.2 cm (h) x 56-56.8 cm (w) x 55 cm (d)

Model Overview:

- 43 l capacity
- DirectControl with retractable dial and 4-line clear text TFT
- 8 functions including 1,000 W microwave
- Easy cleaning - Compartment has PerfectClean and linen structure
- Quick preparation - combined microwave modes
- Speed ovens - Combining operating mode and microwave power can save up to 30% cooking time
- Electronic temperature control - the temperature selected is constantly monitored and maintained
- Automatic programmes - The simple way to perfect results
- Fresh popcorn at your fingertips thanks to the Popcorn button
- 3 rack levels
- PerfectClean

IMPORTANT: Please measure your appliance cavity prior to purchase to ensure your chosen appliance will fit. A restocking fee may apply for returned appliances due to incorrect size purchase.

Miele

CLEAN STEEL SPEED OVEN W.600

H 6400 BM INSTALLATION DRAWINGS



- * Appliances with glass front
- ** Appliances with metal front

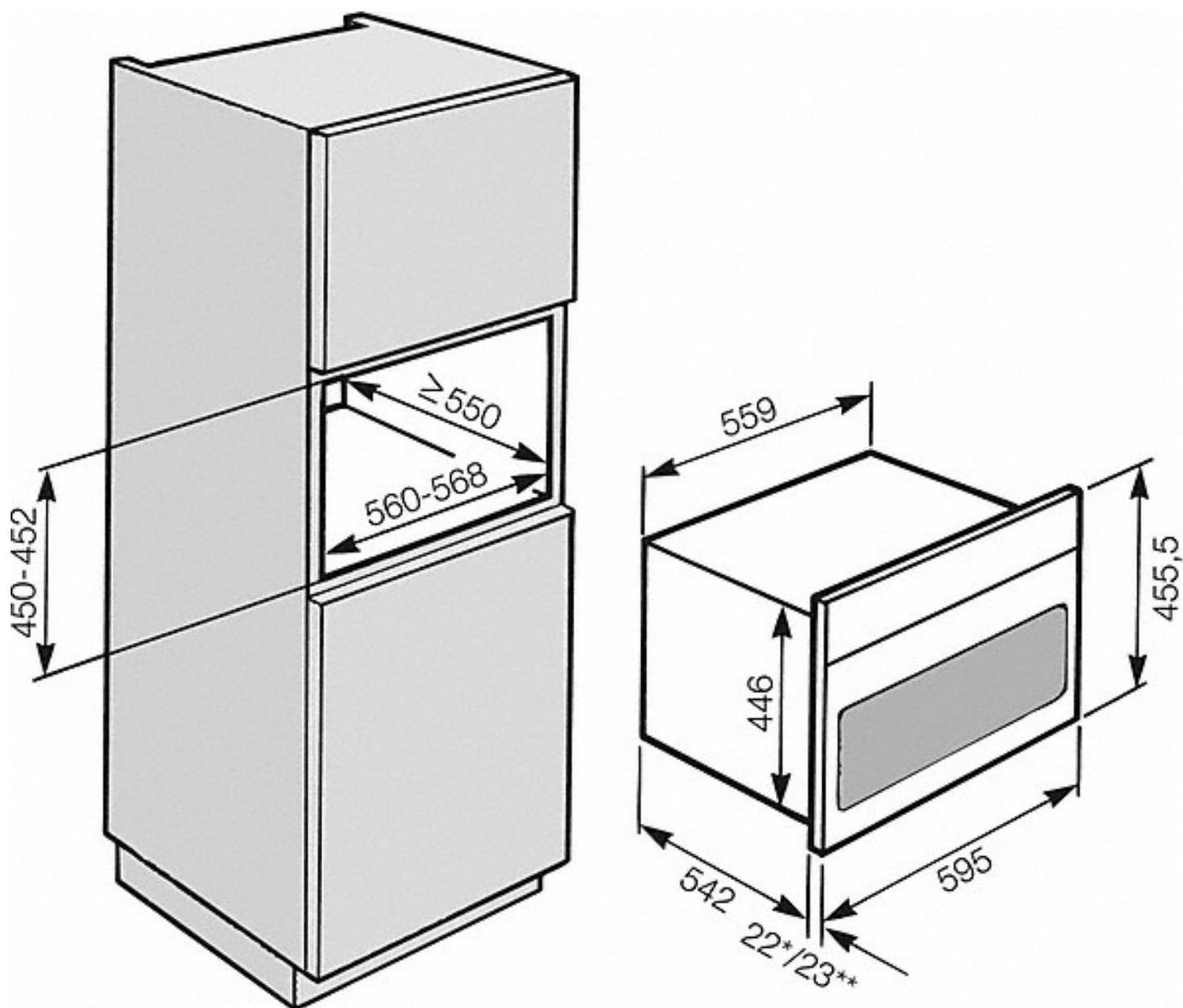

Miele

