

---

# ICNh 5133

---

Integrated fridge-freezer with  
EasyFresh and NoFrost

# LIEBHERR

Fully Integrated



Fully Integrated

# ICNh 5133

Plus

Fully Integrated

## Features

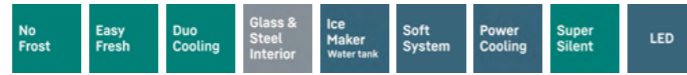

<b>Gross/net capacity</b>	
Total gross/net capacity	273/249 litre
Fridge compartment	182 litre
Freezer compartment	67 litre
Temperature rise time	9 h
Freezing capacity in 24 hours	6 kg
Climate rating	SN-T (+10°C to +43°C)
Noise output	34 dB(A)
Frequency/voltage	50-60 Hz / 220-240 V~
Connection Rating	1.4 A 183 W
<b>Fridge compartment</b>	
Forced air system	FreshAir activated charcoal filter
Interior light	LED ceiling light
VarioSafe	yes
Fruit and vegetable bins	1 EasyFresh-Safe on running rails
Bottle shelf	3 bottle shelf
<b>Freezer compartment</b>	
Defrosting	automatic
Number of drawers	3 drawers, VarioSpace
IceMaker	yes
Ice cube capacity in 24 hours	1.2 kg
Ice cube stock	5.0 kg
<b>Type of appliance</b>	
Type	Built-in for integrated use
Door assembly	Door on Door
<b>Dimensions</b>	
Height	177.2-178.8 cm
Width	56-57 cm
Depth	min. 55 cm
<b>Features</b>	
Interface	SmartDeviceBox: optional accessory (Only available in selected countries)
Door hinges	right, reversible
EAN-Nr.	4016803078913



### NoFrost

When you open your freezer, you want to see frozen food – and certainly not ice and frost. NoFrost protects the freezer compartment from unwanted icing, which consumes a lot of energy and can be expensive. NoFrost means no more tedious and time-consuming defrosting of the freezer compartment, more time for other things – and saving money.



### EasyFresh

The guarantee of market freshness in the home is our EasyFresh-Safe. Whether it's unpackaged vegetables or fruit, this ensures optimal storage for everything. Thanks to the air-tight closure, the food causes the humidity in the safe to rise. This keeps the food fresh for a long time.



### DuoCooling

DuoCooling uses two completely separate refrigeration circuits to ensure no air is exchanged between the fridge and freezer compartments. The food neither dries out nor is odour transferred. This means throwing less away, shopping less often, but saving more and greater enjoyment.



### Touch display

Fingertip control: the touch display enables easy and intuitive operation of your Liebherr. All functions are clearly arranged on the display. By gently tapping a finger, for example, you can easily select the functions or check the current temperature of your refrigerator.



### SmartSteel rear wall

The rear wall in elegant SmartSteel gives your Liebherr a stylish look and feel. Your food will also love SmartSteel as stainless steel is food-safe and hygienic. SmartSteel also reduces the visibility of fingerprints – making the appearance even more pleasing.



### IceMaker with water tank

Whether it's for a party or a spontaneous cocktail, the integrated IceMaker means you always have enough ice cubes in stock. With the IceMaker with water tank, you simply fill the removable water tank with water. The MaxIce function allows you to produce up to 1.5 kg of ice cubes a day. The ice cube separator helps to divide the drawer as you wish, for example, ice cubes on the left, ice cream on the right.

# Diagrams

## Installation Diagram

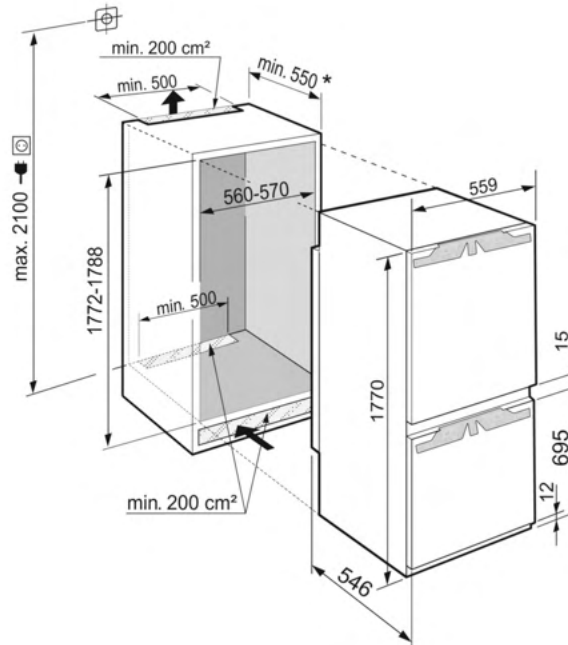

\* Recommended: 560 mm

Products and their details are staged for advertising purposes. Whilst every effort is made to ensure all specifications and information in this flyer are accurate, Liebherr reserves the right to make changes without notification. Where actual appliance measurements, specifications, and ratings are crucial, we recommend that the actual appliance installation instructions that accompany each appliance be checked. Liebherr will not be liable for any loss. (22.02.2022)