

KFN 15842 D edt/cs

Freestanding fridge-freezer

75 cm wide for plenty of storage space.



- Optimum and maintenance-free LED lighting in compartment
- High level of economy with perfect freshness – A++
- No icing up of food and no need to defrost thanks to Frost free
- Easy and effortless opening of refrigerators thanks to EasyOpen

Appliance category	
Fridge-freezer	•
Construction type	
Freestanding appliance	•
Door hinge	right
Convertible door hinging	•
Design	
Casing colour	Stainless steel look
Front colour	Stainless steel/CleanSteel
Refrigeration section lighting	LED
User convenience	
ComfortClean	•
DynaCool	•
NoFrost	•
DuplexCool	•
VarioRoom	•
SoftClose	•
Concealed door opener	EasyOpen lever handle
Controls	
Operating concept	TouchControl
Fridge compartment can be switched off	•
Independent temperature regulation of fridge and freezer zones	•
Automatic SuperCool	•
SuperFreeze	•
No. of temperature zones	2
Sabbath mode	•
Fridge/Fridge section	
Height-adjustable tempered glass shelves	•
No. of shelves	4
Chrome-plated metal bottle rack	•
No. of vegetable drawers	Qty 2
of which on castors	2
Half-width door shelves	4
Door rack for bottles	1
Freezer/Freezer section	
Number of freezer drawers/baskets	Qty 2
Safety	
Lock function	•
Acoustic door alarm	•
Acoustic temperature alarm, freezer section	•
Optical door alarm	•
Optical temperature alarm	•
Power cut indication for freezer section	•

KFN 15842 D edt/cs

Freestanding fridge-freezer

75 cm wide for plenty of storage space.



Technical data	
Niche width in mm	762
Niche height in mm	1,873
Appliance width in mm	750
Appliance height in mm	1,859
Appliance depth in mm	630
Climate class	SN-T
Refrigerator compartment in l	331
4* freezer compartment in l	82
Storage time in case of fault	24
Freezer capacity in kg/24 h	8.0
Current consumption (mA)	1,500
Voltage in V	220-240
Fuse rating in A	10
Length of supply lead in m	2.4
Standard accessories	
Butter dish	•
Egg tray	•
Ice packs	•
Ice cube tray	•

KFN 15842 D edt/cs

Freestanding fridge-freezer

75 cm wide for plenty of storage space.

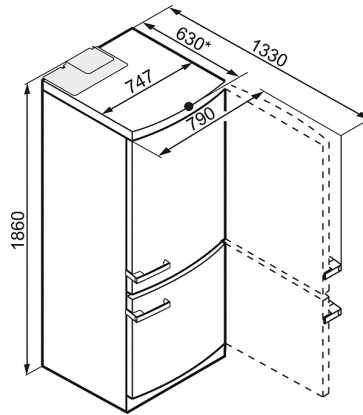

KFN14842SDed/cs-1 (installation drawings) (*footnote)

*To ensure that energy consumption as stated is achieved, machines should be used together with the enclosed spacer brackets. This increases the total depth of the unit by approx. 3.5 cm. Machines are still fully functional when operated without these brackets but have a slightly higher energy consumption.