

Warming drawer, 60 x 29 cm, Stainless steel  
N17HH20NOB

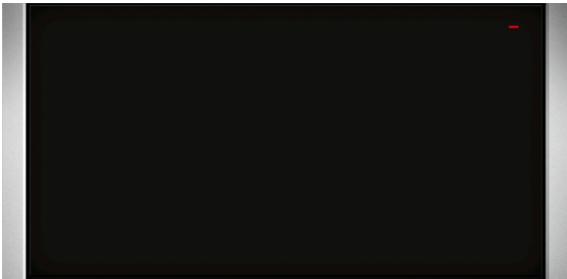

COOKING PASSION SINCE 1877



Warming drawer with 29 cm installation height - perfect for a coordinated kitchen look

✓ Push & Pull – One gentle touch opens and closes your drawer.

#### Features

##### Technical Data

Color / Material Front : Stainless steel

Built-in / Free-standing : Built-in

Dimensions : 290 x 596 x 548 mm

Dimensions of the packed product (HxWxD) : 350 x 650 x 650 mm

Min. required niche size for installation (HxWxD) : 290 x 560 x 550 mm

Maximum number of plates : 40

Maximum number of espresso cups : 192

Net weight : 19.5 kg

Gross weight : 21.2 kg

EAN code : 4242004184645

Electrical connection rating : 810 W

Fuse protection : 10 A

Voltage : 220-240 V

Frequency : 60; 50 Hz



4 242004 184645

Warming drawer, 60 x 29 cm, Stainless steel  
N17HH20NOB

## Features

### Design

- Heating plate made of toughened glass
- Temperature control with 4 levels: 40 °C - 80 °C (glass surface temperature)
- Suitable for:
  - Dough proving - Defrosting - Keeping drinks and food warm - Pre-warming of crockery - Slow cooking

### Convenience

- Cavity volume: 52 l
- Max weight up to 25 kg
- Max. loading espresso cups: 192 PC or Max. loading plates: 40 PC
- Rotary Control Knobs

### Technical Information

- Length of mains cable: 150 cm
- Total connected load electric: 0.81 KW
- Nominal voltage: 220 - 240 V

### Dimensions:

- Appliance dimension (HxWxD): 290 mm x 596 mm x 548 mm
- Installation dimensions (HxWxD): 290 mm x 560 mm - 568 mm x 550 mm
- Please reference the built-in dimensions provided in the installation drawing

Warming drawer, 60 x 29 cm, Stainless steel  
N17HH20NOB

Dimensioned drawings

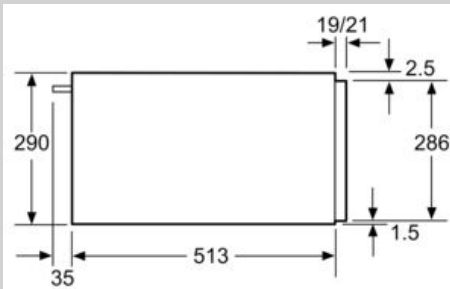

Ovens with an appliance height of 595 mm can be installed above a warming drawer. An intermediate floor is not required.

measurements in mm

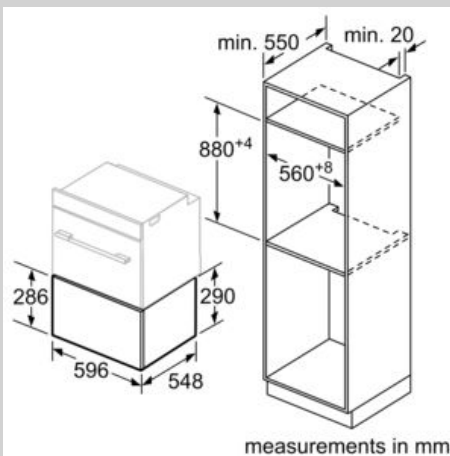

measurements in mm