



6-BURNER, ELECTRIC OVEN 90 CM PRO90 6 MFE S XT

- The original Bertazzoni Professional Series model wide format give great versatility and style to your kitchen.
- The oven has 11 functions, from convection, baking and grilling to fast-preheat. Triple-glazed oven doors feature soft motion hinges and anti-slam closing system, and also minimise heat loss.
- The hob has six versatile gas burners in brass including a dual-ring power burner giving anything from a delicate low simmer to full power.
- Products and packaging are 99% recyclable.

SPECIFICATIONS

Worktop

Size:	90 cm
Cooking zones:	6
Gas zones:	6
Worktop type:	gas
Worktop design:	stainless steel squared
Worktop controls:	knobs
Knobs:	metal coated
Burner type:	brass
Pan supports:	cast iron
Continuous grating:	yes
Flame failure device:	yes
One-hand ignition:	yes
Worktop handrail:	yes
Upstand:	yes
Wok adapter:	yes
Simmer ring:	yes

Cooking Zones:

Dual wok:	0.48 kW - 5 kW
Rapid:	1.05 kW - 3 kW (1)
Semi-rapid:	0.60 kW - 1.75 kW (3)
Auxiliary:	0.48 kW - 1 kW (1)

Oven Cavity

Oven configuration:	single
Oven fuel:	electric
Oven type:	electric multifunction



SPECIFICATIONS

Oven grill type:	electric
Oven functions:	bake bottom bake convection convection bake convection grill defrosting dehydrate fast preheat grill oven light pizza upper bake
Oven volume:	103 l
Oven convection system:	single with heating element
Oven energy rating:	A
Oven controls:	knobs touch digital programmer
Inner oven door:	triple
Removable inner glass:	yes
Cooling fan:	yes
Oven levels:	4
Timer:	touch digital programmer
Food probe:	yes
Oven door closing:	anti-slam system
Sliding shelves:	1 standard
Wire-shelves:	2 heavy gauge chromed
Tray:	1 enamelled
Grill trivet for tray:	yes
Oven lights:	double
Storage compartment:	drawer
Legs:	stainless steel
Electrical requirements:	220/240 V - 50/60 Hz - 16 A
Nominal power:	3500 W
Energy rating:	A



SPECIFICATIONS

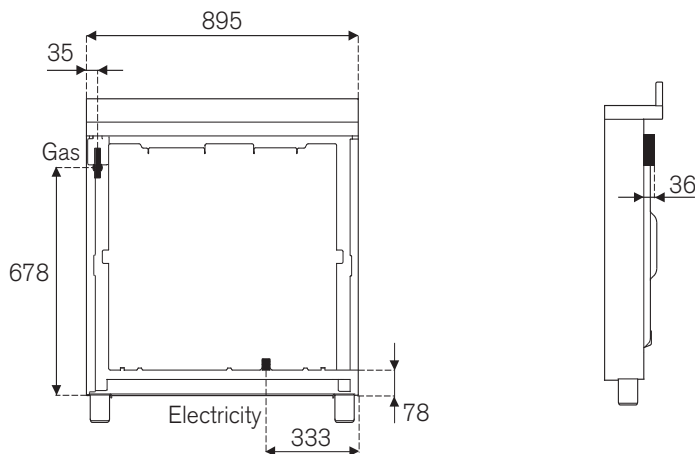
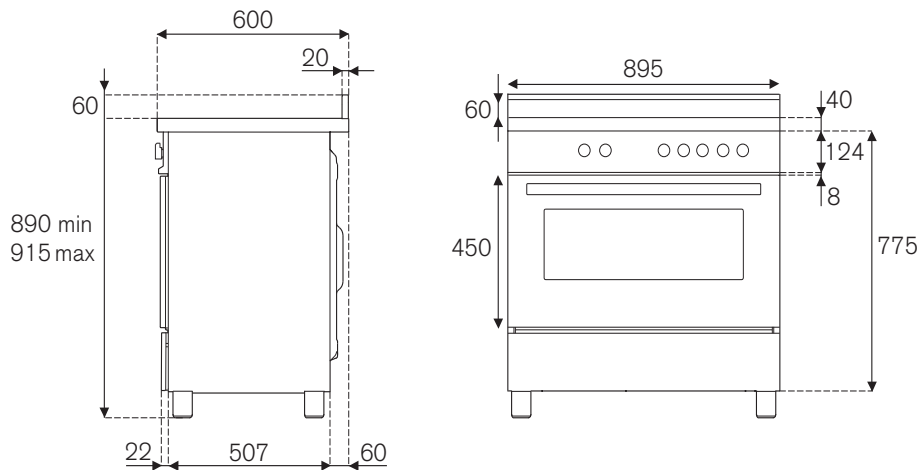
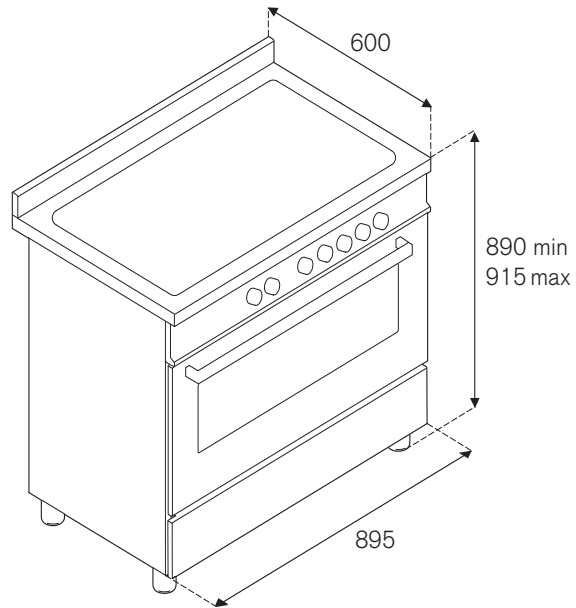

D174 - C80S