



#### Color Variants

RB492504

With fresh cooling close to 0 °C

Fully integrated

#### Included accessories

1 x egg box with lid.

1 x ice cube scoop.

RB492504

Vario fridge-freezer combination 400 series

With fresh cooling close to 0 °C

Fully integrated

Niche width 91.4 cm, Niche height 213.4 cm

Cooling section with one door and one fully extendable freezing drawer



Stainless steel interior with solid anthracite aluminium elements  
Warm white and glare-free LED light spots

Opening assist for door with two options:

1. Push-to-open function for integration into handleless furniture front
2. Pull-to-open function to facilitate opening the door using a handle

Flat stainless steel inner door, full-length

Almost invisible rail system for shelves and door racks for flexible positioning

Solid anthracite aluminium door racks  
1 fresh cooling drawer close to 0 °C with manually adjustable temperature

and one fresh cooling drawer with manually adjustable humidity

Integrated ice maker with fixed inlet water connection

Fully extendable freezer drawer with practical divider in anthracite

TFT touch display

#### Handling

TFT touch display operation.

Clear text display.

#### Technical Features

Gross volume 637 l litres total

Dynamic cold air distribution.

Automatic defrosting with defrost water evaporation.

Cushioned door closing system.

Activated charcoal air filter.

When rest mode is active, the appliance can only be opened using a handle.

Open-door and malfunction alarm.

Home network integration for digital services (Home Connect) wireless via WiFi.

The use of the Home Connect functionality depends on the Home Connect services, which are not available in every country. For further information please check: home-connect.com.

#### Cooling

No-Frost technology with fast cooling. Temperature adjustable from +2 °C to +8 °C.

Flat door rail system with fully flexible positioning of door racks.

3 height adjustable door racks, 1 of which is extra deep.

Net fridge capacity total: 381 l litres.

#### Fresh cooling close to 0 °C

1 fully extendable fresh cooling drawer close to 0 °C with transparent front, illuminated.

Cushioned closing system.

Temperature can be adjusted manually. Ideal for meat, fish and poultry.

Net volume 34 litres.

#### Fresh cooling

1 fully extendable fresh cooling drawer with transparent front, illuminated.

Cushioned closing system.

Humidity can be adjusted manually. Ideal for fruit and vegetables.

#### Freezing

No-frost technology with fast freezing at -30 °C.

Temperature adjustable from -14 °C to -24 °C.

Freezing capacity 16 kg/24 h.

#### Characteristics

Energy Efficiency Class (Regulation (EU) 2017/1369)

E

Average annual energy consumption in kilowatt hour per year (kWh/a) (EU) 2017/1369

326

Sum of volume of frozen compartments (EU 2017/1369)

166

Sum of volume of chill compartments (EU 2017/1369)

389

Airborne acoustical noise emissions (EU 2017/1369)

42

Airborne acoustical noise emission class (EU 2017/1369)

D

Built-in / Free-standing

Built-in

Number of compressors

2

Number of independent cooling systems

2

Width of the product

908

Height

2125

Depth of the product

608

Net weight

204.2

Required niche size for installation (HxWxD)

2134.0 x 914.0 x 610

Door panel options

Not possible

Door hinge

Right reversible

Number of Adjustable Shelves in fridge compartment

2

Shelves for Bottles

No

Frost free system

Interior ventilator

Yes

Reversible Door Hinge

Yes

Length electrical supply cord

300

Noise level

42

Multi-Flow Air Tower

Yes

Fast cooling switch

Yes

Fast freezing switch

Yes

Carbon Air Filter

No

Temperature Controlled Drawer

No

Humidity Control Drawer

No

Number of Door Bins - Refrigerator

3

Door bin adjustability - Refrigerator

No

Tilt-out door bins in fridge

No

Number of Gallon storage

1

No. of shelves in fridge

3

Number of shelves - Freezer

Shelf Adjustability - Freezer

No

Capacity of Water Tank

Connection Rating

300

Fuse protection

10

Voltage

220-240

Frequency

50-60

Energy consumption

Freezing capacity

Storage Period in Event of Power

Storage time after a malfunction 17 h.

2 fully extendable inside drawers.

Interior lighting with 2 LED light spots, warm white light.

Net volume 166 litres.

#### Ice maker

Integrated in the freezer compartment, with fixed inlet water connection.

Particle filter for water inlet, integrated in ventilation grille area.

Saturation indicator shown in TFT touch display.

Can be switched off.

Ice cube production approx. 1.6 kg/24 h.

Removable ice storage container with approx. 3 kg capacity.

#### Consumption data

5 stars.

Energy consumption 336 kWh/year.

Noise level 42 dB (re 1 pW).

#### Planning notes

Flat hinge.

Door hinge right, reversible.

Door opening angle of 115°, fixable at 90°.

Shut-off valve for water connection must be planned next to the appliance and always be accessible.

If the water pressure exceeds 0.8 MPa (8 bar), connect pressure relief valve between water tap and hose set.

#### Connection

Total connected load 0.300 KW.

Connecting cable 3.0 m, detachable.

Water inlet.

Supply hose 2.0 m with 3/4 " connection.

Water pressure 2 to 8 bar.

Rest mode certified by Star-K.

**GAGGENAU**

RB492504

Vario fridge-freezer combination 400 series

With fresh cooling close to 0 °C

Fully integrated

Niche width 91.4 cm, Niche height 213.4 cm

Cooling section with one door and one fully extendable freezing drawer

2022-02-21

Page 2

Wall clearance RB 492/RV 492

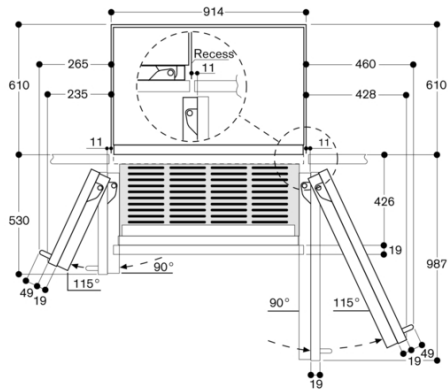

In the drawing, a unit front thickness of 19 mm and a Gaggenu handle of 49 mm were taken as a basis.

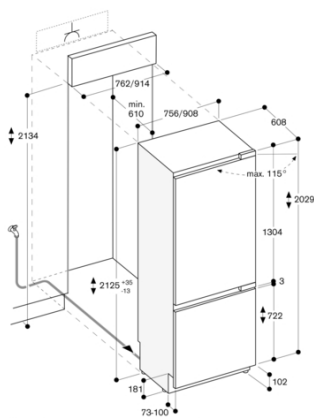
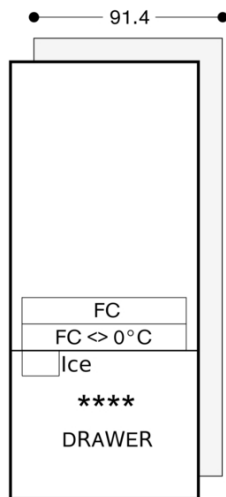

The maximum door panel dimensions are based on a clearance of 3 mm.

**GAGGENAU**