



Color Variants

RY492504

Included accessories

1 x egg box with lid.
1 x ice cube scoop.

Optional accessories

RA430100
Storage container with transparent lid,
anthracite.

RA450000
Mechanical particle filter

RA450010
Activated charcoal filter for water filter
system including saturation indicator

Installation Accessories

RA421912
Stainless steel door panel with handles

RA423340

RA425110
Long stainless steel door handle

RA425910
Short stainless steel door handle

RA428912

RA460000
Installation kit for side-by-side
installation (for connecting any two
columns)

RA460013

RA460030
Connecting element for vertically split
fronts (for fridge-freezer combination
with one door)

RA464910

Ventilation grill, stainless steel

Product Features

Construction type

Built-in

Number of compressors

2

Number of independent cooling systems

2

Width of the product (mm)

908

Height (mm)

2125

Depth of the product

608

Net weight (kg)

220.096

Required cutout size (HxWxD) (mm)

2134.0 x 914.0 x 610

Panel ready

Not possible

Door Hinge

left and right

Adjustable Shelves - Refrigerator

2

Shelves for Bottles

No

Frost free system

Fridge and freezer

Interior ventilator

No

Reversible Door Hinge

No

Power cord length (cm)

300

Silence level (dBA)

41

Multi-Flow Air Tower

Yes

SUPERCOOL

Yes

SUPERFREEZE

Yes

Carbon Air Filter

No

Temperature Controlled Drawer

No

Humidity Control Drawer

No

Number of Door Bins - Refrigerator

6

Adjustable Door Bins - Refrigerator

No

Tilt-Out Door Bins - Refrigerator

No

Gallon Storage Bins

2

No. of shelves in fridge

3

Number of Shelves - Freezer

Adjustable Shelves - Freezer

No

Capacity of Water Tank [l]

Consumption and connection features

Watts (W)

300

Current (A)

10

Volts (V)

220-240

Frequency (Hz)

50-60

Energy consumption (kWh)

Freezing capacity (kg)

Storage Period in Event of Power Failure (h)

17

Approval certificates

CE, VDE

UPC code

Color / Material housing

Panel ready

Not possible

Silence level (dBA)

41

Total annual energy consumption (kWh)

Energy Star® qualified

No

Power Cord Length

Required cutout size (HxWxD) (in)

84" x 36" x 24 3/4"

GAGGENAU

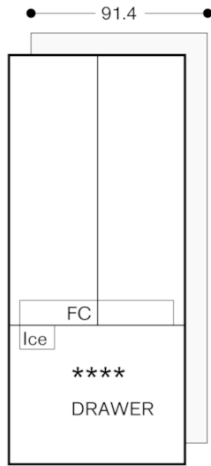

Wall clearance RB 492/RV 492

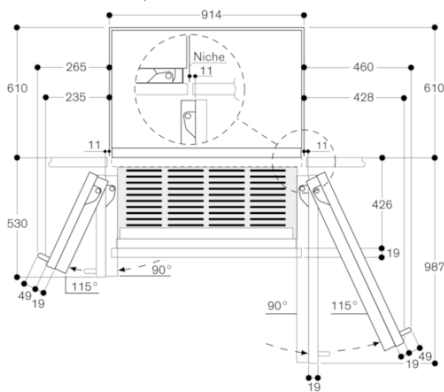

In the drawing, a furniture front thickness of 19 mm as well as the height of a Gaggenau furniture handle of 49 mm is assumed.

Door opening angle

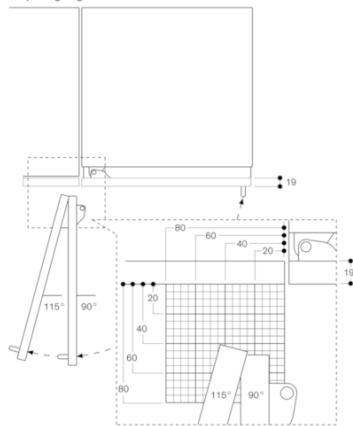

The hinge path and the resulting distances to the neighboring furniture and furniture handles can be taken from the drawing depending on the front thickness. In the drawing, a furniture front thickness of 19 mm is assumed.

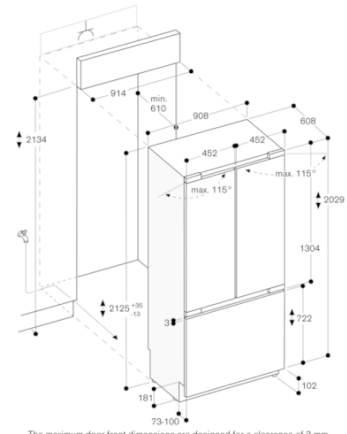

The maximum door front dimensions are designed for a clearance of 3 mm.

Base details

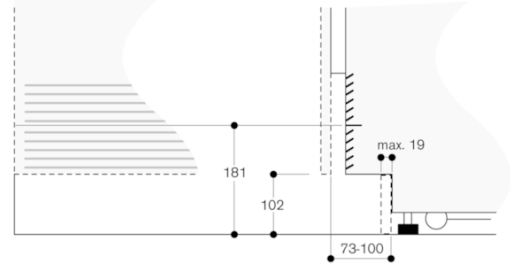

In relation to the standard height of the appliance, the height of the toe kick plate is 102 mm. Maximum thickness of the toe kick plate is 19 mm.

