



The Smooth Operator

Quality, Design and Innovation

LIEBHERR

SUIKo 1550



Door-on-door technology: Allows custom panels to be affixed directly onto the appliance door so that the hinges are concealed, plus the cabinet and the fridge door open as one, ensuring a wide range of design options and easy installation.



SoftTelescopic: A highly practical self-retracting, self-closing feature. Our SoftTelescopic technology guarantees elimination of slamming even when the shelf is fully loaded.



Touch control system: Our intuitive electronic touch control panel ensures all functions are easy and convenient to use as well as guarantees that the settings selected remain accurate and constant.

The precision control system of the **SUIKo 1550** creates a stunning visual impact and enhances the ease and convenience of use. The SuperCool function quickly reduces the temperature of the fridge compartment; ideal for rapidly cooling down freshly stored food. The innovative LED light and the special satin finish of the light cover produces a pleasant lighting atmosphere.

The pull-out fridge compartment is mounted on soft telescopic rails. It has a practical bottle shelf and a removable fruit and vegetable drawer. The large drawer can also be divided into two equal-sized compartments, with more storage space underneath.

Additionally you can opt for our high-quality, easy-to-fit stainless steel panel and handle¹ which enable the model's seamless integration into any kitchen!

SUIKo 1550
Premium

Soft
Telescopic

Energy consumption (kWh/y)	158
Sound rating dB(A) *	37
Refrigerator capacity litre	124
Number of shelves	2
Fruits and vegetable bins	1
Electronic control	MagicEye on front, key electronic
Refrigerator temperature range °C	+2°C to +9°C
Defrost type	Automatic
Interior light	LED ceiling light
Door alarm	Visual and audible
Door type	Steel
Integrated lock	No
SoftSystem	No
Door hinges	Pull-out
Product dimensions (H/W/D) cm	82 - 88 / 59.7 / 55
Cut out dimensions (H/W/D) cm	82 - 88 / 60 / min. 55
Gross / Net weight kg	46.4 / 41.5
Voltage V/Hz	220-240 / 50

Installation Diagram

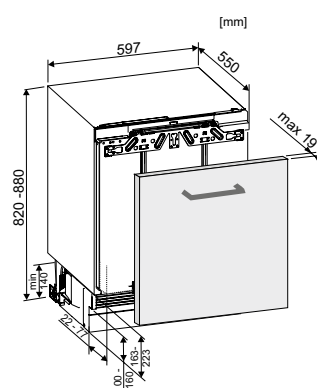

Ventilation Diagram

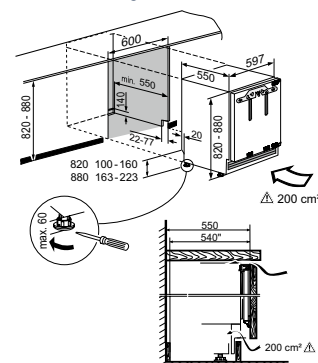

- The airflow cavity must be at least 200 cm²
- The unit's energy consumption will increase if there is insufficient air flow.

* Noise output - according to EN 60704-3

¹ Optional accessories: Stainless Steel Panel (Part no. 990043200), Stainless Steel Handle (Part no. 990152700)

Subject to modification. Current data see home.liebherr.com