

N 90, Induction hob, 90 cm, Black
T59TS61N0

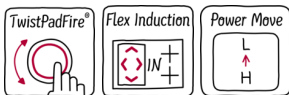
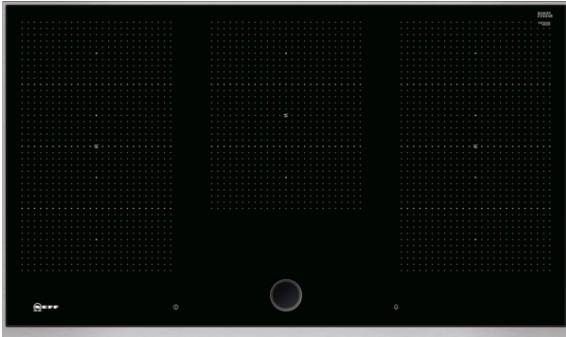

Standalone FlexInduction cooktop with TwistPad® Fire control.

- ✓ TwistPadFire® – our removable, magnetic, illuminated control dial that gives you precise control over all cooking zones.
- ✓ The FlexInduction zone automatically detects the number, size and shape of the pots and pans used and heats up precisely where it's needed.
- ✓ Power Move – the flex zone offers three heating zones: boiling in front, simmering in the middle and warming in the rear.
- ✓ Induction – the heat is generated directly in the cookware for precise cooking that stops when power is off.
- ✓ The FlexInduction zone automatically detects the number, size and shape of the pots and pans used and heats up precisely where it's needed.

Features

Technical Data

Product name/family : Cooking zone ceramic
 Construction type : Built-in
 Energy input : Electric
 Total number of positions that can be used at the same time : 5
 Required niche size for installation (HxWxD) : 51 x 880-880 x 490-500
 Width of the appliance : 918
 Dimensions : 51 x 918 x 546
 Dimensions of the packed product (HxWxD) (mm) : 126 x 1073 x 603
 Net weight (kg) : 21.405
 Gross weight (kg) : 23.2
 Residual heat indicator : Separate
 Location of control panel : Hob front
 Basic surface material : Ceramic
 Color of surface : Black, Stainless steel
 Color of frame : Stainless steel
 Approval certificates : AENOR, CE
 Length electrical supply cord (cm) : 110
 EAN code : 4242004189374
 Electrical connection rating (W) : 11100
 Voltage (V) : 220-240
 Frequency (Hz) : 50; 60

Optional accessories

Z9410X1	Stainless Steel roaster with glas lid
Z9415X1	Steaming Rack for Stainless Steel roaste
Z9416X2	Griddle Plate
Z9417X2	Teppan Yaki (large)
Z943SE0	Set of 2 pots and 1 pan
Z9453X0	System pan diameter 21cm



N 90, Induction hob, 90 cm, Black

T59TS61N0

Features

Handling

- TwistPad® Fire

Flexibility

- 2x 3 Flex zones
- 5 induction zones
- Cooking zones: 1 x Ø 400 mmx240 mm, 3.3 KW (max. Power level 3.7 KW) Induction or 2 x Ø 200 mm, 2.2 KW (max. Power level 3.7 KW) Induction; 1 x Ø 300 mmx240 mm, 2.6 KW (max. Power level 3.7 KW) Induction; 1 x Ø 400 mmx240 mm, 3.3 KW (max. Power level 3.7 KW) Induction or 2 x Ø 200 mm, 2.2 KW (max. Power level 3.7 KW) Induction

Comfort & Convenience

- PotBoost function for all cooking zones
- PanBoost
- PowerMove
- FryingSensor with 5 temperature settings
- 17 power levels for each cooking zone
- Residual heat indicator: Digital 2-step
- LED display and timer with auto switch off for all cooking zones, Count-up timer, Alarm clock
- Automatic pan recognition sensor powerManagement Function
Automatic safety switch-off Child safety lock Wipe protection function
- ReStart function
- QuickStart - Quick and automatic first pot detection
- Keep warm function for all cooking zones
- Energy consumption display

Design

- Frameless with front faceted glass

Technical Information

- 90 cm width
- Installation measurements: 880 mm x 490 mm
- Length wire connection: 110 cm
- Min. worktop thickness: 16 mm
- 11.1 KW total connected load
- Voltage: 220 - 240 V
- Cable included

N 90, Induction hob, 90 cm, Black
T59TS61N0

Dimensioned drawings

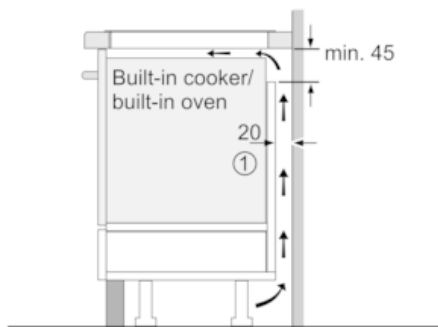

① Ventilation gap must be present

All measurements in mm

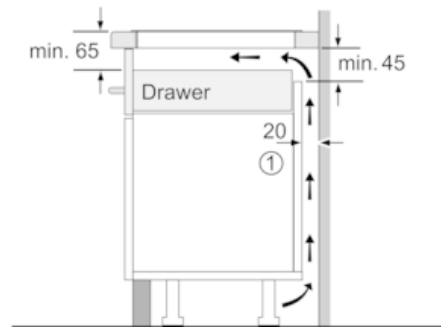

① Ventilation gap must be present.

Measurements in mm

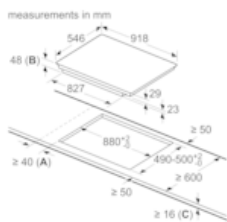

A: Minimum distance from the hob cut-out to the wall.
B: Recessed depth.
C: The clearance between the surface of the worktop and the top of the front of the oven must be 30 mm. See space requirements for the oven.
The worktop into which the hob is installed must withstand loads of approx. 60 kg; suitable substructures must be used if required.

