

**TRIPLE MOTOR
DUCTING**

I/I: Inside to Inside
Measurement

NOTE:

This Zinc Alume Strip is provided to join some duct pieces together. It will be clearly shown on the drawing of the piece it is supplied with.

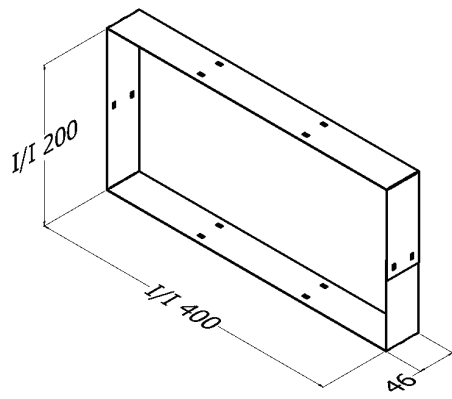

<p>301. 3MT-DL-3 Three Motor Transition to DL-3</p>	<p>302. DL-3 Triple Motor Duct Length</p>	<p>303. HB-3 Horizontal Bend Triple Motor 90°</p>
<p>304. HB-3/45 Horizontal Bend Triple Motor 45°</p>	<p>305. VB-3 Vertical Bend Triple Motor 90°</p>	<p>306. VB-3/45 Vertical Bend Triple Motor 45°</p>
<p>307. TT-3 Triple Motor Twisted Transition</p>	<p>308. TMT-400x200/350 Triple Motor Transition DL-3 to 3500</p>	<p>309. TR-3 Triple Motor Transition to 3500</p>
<p>310. DR-350 Duct Length 3500</p>	<p>311. DR-350 CB Duct Length 3500 Colourbond</p>	<p>312. DR-350/45 3500 Bend 45°</p>

▲ TRIPLE MOTOR

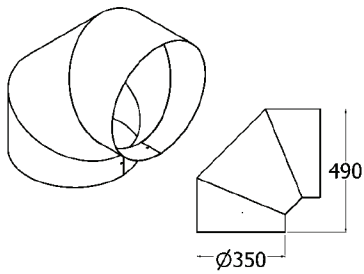

313. DR-350/90
3500 Bend 90°

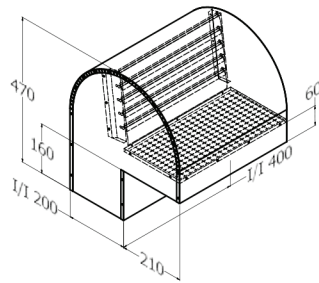

314. BD/RC-3
Back Draft Roof Cowl Triple Motor

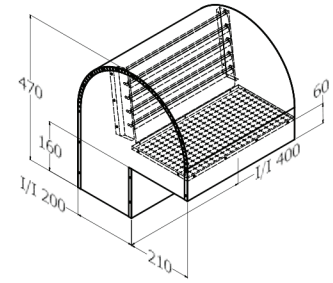

315. BD/RC-3 SS
Back Draft Roof Cowl Triple Motor
445M2 Stainless Steel

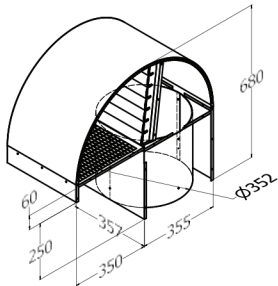

316. BD/SQ-RC 350
Back Draft Roof Cowl Triple Motor 350S0

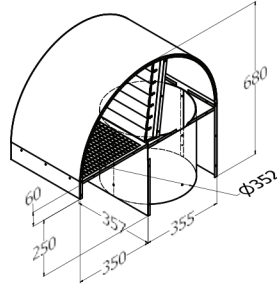

317. BD/SQ-RC 350 SS
Back Draft Roof Cowl 3500
445M2 Stainless Steel

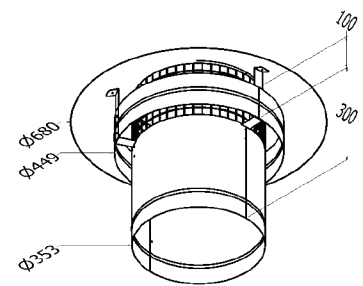

318. CH-350
Chairmans Hat 3500

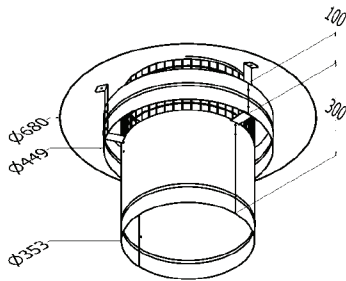

319. CH-350 CB
Chairmans Hat 3500 Colurbond

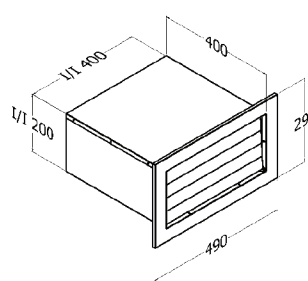

320. BD/WV-H-3
Back Draft Wall Vent Triple Motor Horizontal

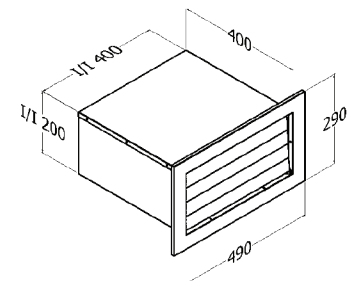

321. BD/WV-H-3 SS
Back Draft Wall Vent Triple Motor Horizontal
445M2 Stainless Steel

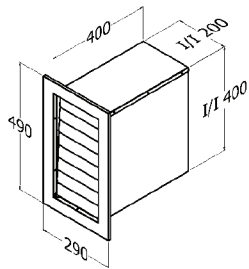

322. BD/WV-V-3
Back Draft Wall Vent Triple Motor Vertical

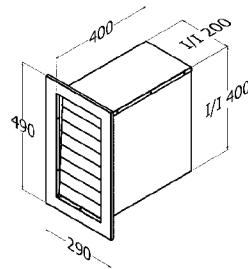

323. BD/WV-V-3 SS
Back Draft Wall Vent Triple Motor Vertical
445M2 Stainless Steel

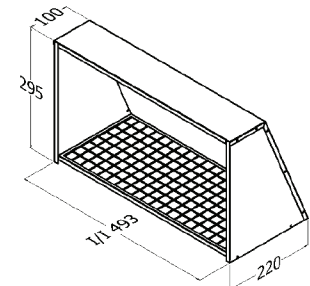

324. WVC-H-3
Wall Vent Cover Triple Motor Horizontal

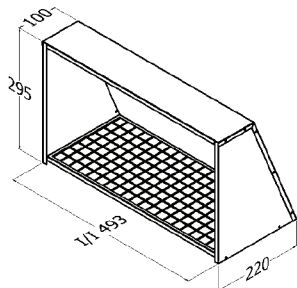

325. WVC-H-3 SS
Wall Vent Cover Triple Motor Horizontal
445M2 Stainless Steel

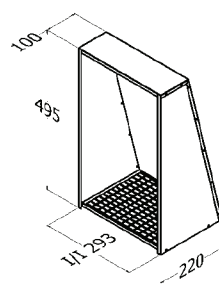

326. WVC-V-3
Wall Vent Cover Triple Motor Vertical

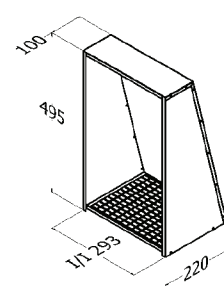

327. WVC-V-3 SS
Wall Vent Cover Triple Motor Vertical
445M2 Stainless Steel

▲ TRIPLE MOTOR

QASAIR RESERVES THE RIGHT TO CHANGE SPECIFICATION WITHOUT NOTICE © IS A REGISTERED TRADE MARK MADE IN RINGWOOD 3134

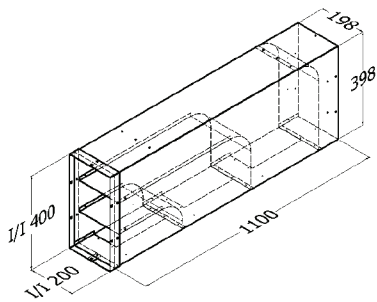

328. DD-3V-L
Duct Director Triple Motor Vertical Left

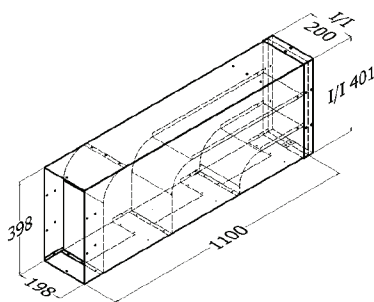

329. DD-3V-R
Duct Director Triple Motor Vertical Right

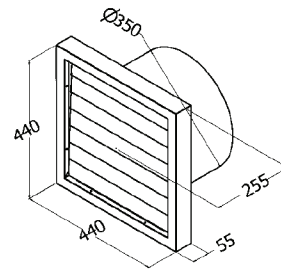

330. BD/WV-350Ø
Back Draft Wall Vent

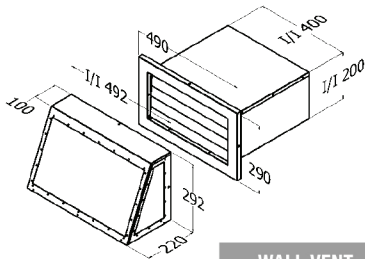

WALL VENT

331. FRWV-H-3 SS
Fire Rated Wall Vent Triple Motor Horizontal

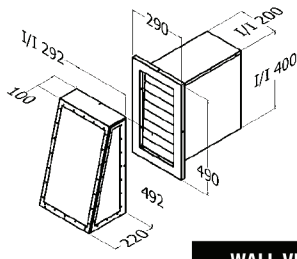

WALL VENT

332. FRWV-V-3 SS
Fire Rated Wall Vent Triple Motor Vertical

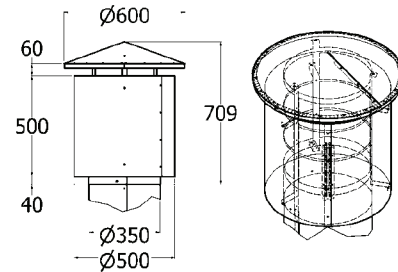

333. FRC 350 SS
Fire Rated Roof Cowl 350Ø 445M2 Stainless Steel

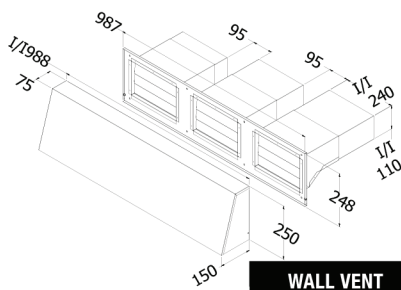

WALL VENT

334. BD/WV/K-H-3
Kit assembled as one piece. Three Single Motor Back Draft Wall Vent Horizontal with telescopic length & cover

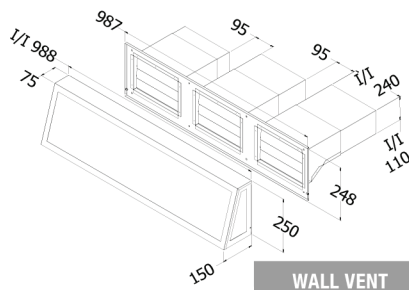

WALL VENT

335. FRWV/K-H-3
Kit assembled as one piece. Fire rated Three Single Motor Back Draft Wall Vent Horizontal with telescopic length & cover

ROOF COWLS, WALL VENTS AND WALL VENT COVERS

All the above ducting pieces are all made in stainless steel type 445M2 which has a chromium content of 22% which is far greater than marine grade stainless steel and provides better protection.

This is stated on the description of each piece in the ducting brochure.

WALL VENT COVERS SPECIFICATIONS FIRE RATED APPROVED

The wall vent covers have stainless steel screening type 316 and meets the requirements for stainless steel screening under the Australian Standard.

AS 3959-2009 Construction of Buildings in Bushfire prone areas.