

INSTALLATION INSTRUCTIONS

1. Cabinet dimensions:
VI50 height 1550mm - 1580mm (30mm adjustable feet)
 width 595mm
 depth 600mm (tube handle protrudes 45mm beyond this)
2. Please note that a minimum cut out of 615mm is required to facilitate installation, removal and servicing.
3. This cabinet requires 10mm clearance on both sides and on top, 50 - 100mm clearance at the rear. If a cupboard is to be placed above the wine cabinet, it must be stood off the wall 50 - 100mm to allow any heat generated by the cabinet to dissipate. See diagram for clarification.
4. Where possible the powerpoint should be offset for easy access. This is not imperative but is advised where the opportunity exists.
5. The power cord is 2.5m in length and is fixed on the right hand side at the back of the cabinet when looking from front.

* It is advised to use a power surge protector in case of electricity supply fault.

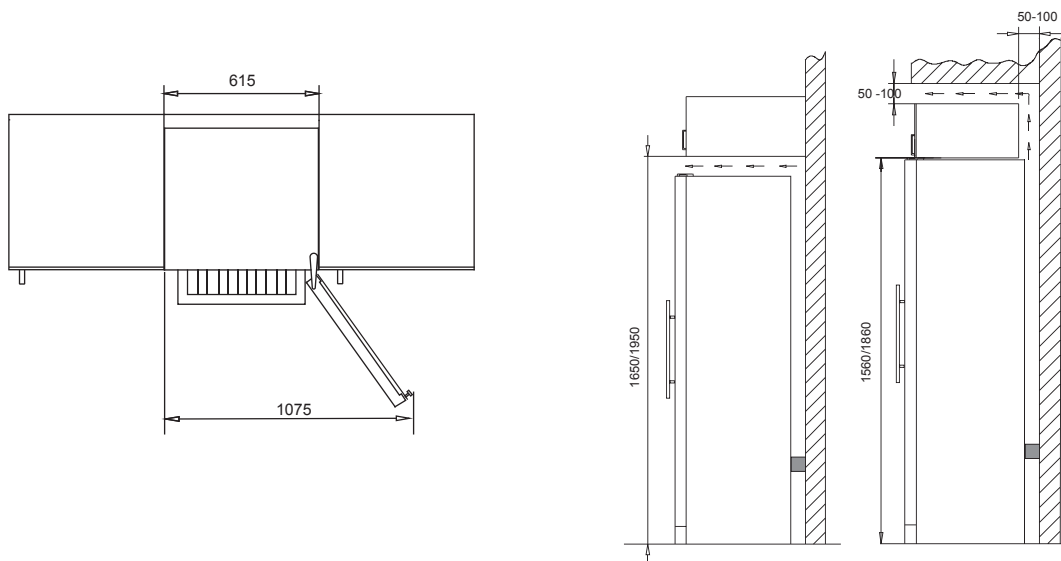

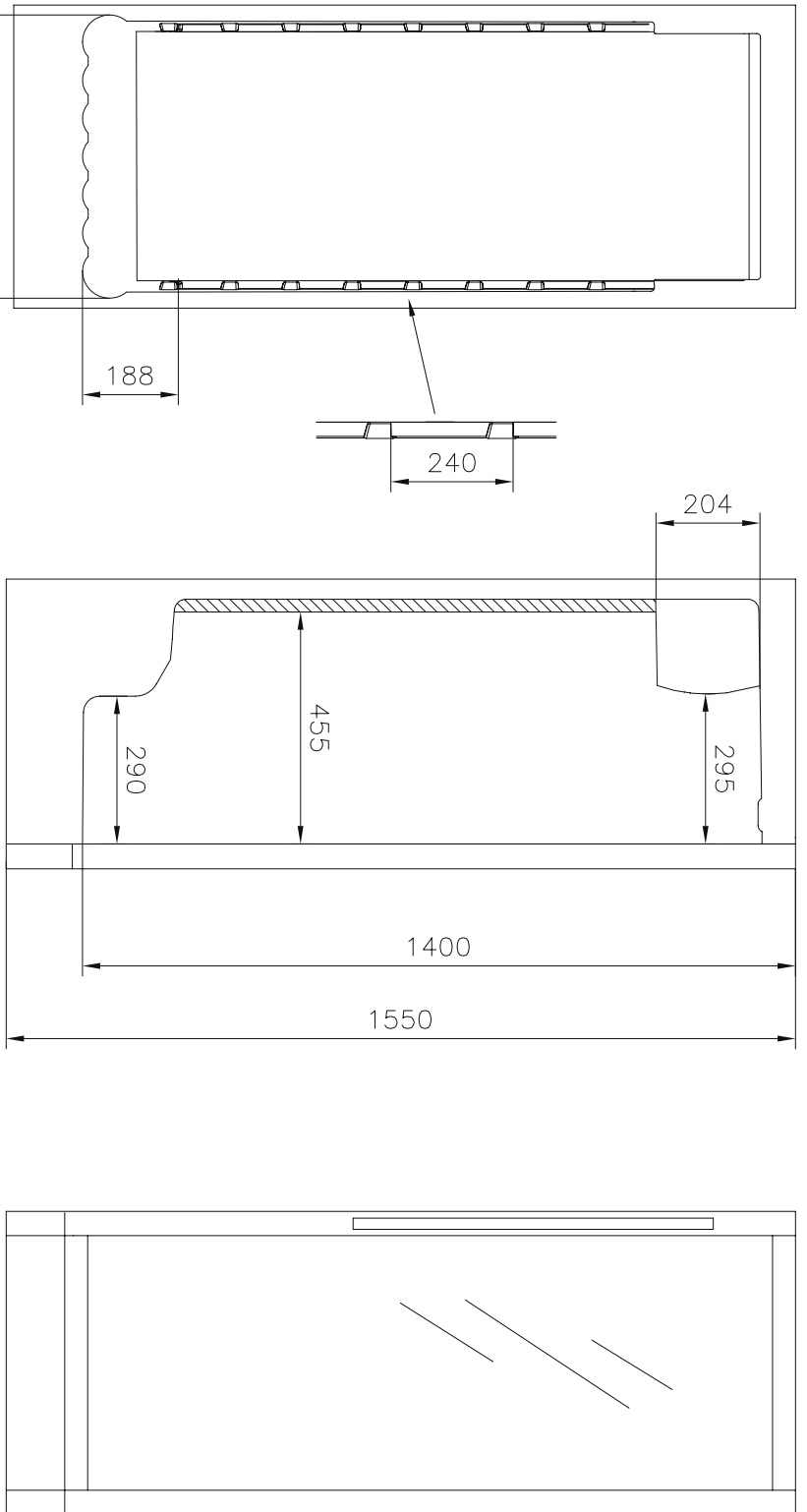

VKG 860

Height : 1550
 Width : 595
 Depth : 595
 Incl. handle : 665
 Incl. open door : 1180
 Shelf of wood : 5 psc.

Alle mål er i m.m.