



#### Color Variants

VR414110

#### Included accessories

1 x cast pan.  
half size.  
1 x grease drip tray.  
2 x cast iron grill.  
1 x lava stones.  
1 x cleaning brush.

#### Optional accessories

LV030000  
VA461000  
VA461001

#### Installation Accessories

VA420000  
VA420001  
VA420010  
VA420011  
VA440010  
VA450400

#### Characteristics

##### Product name/family

Vario/Domino barbecue grill

##### Built-in / Free-standing

Built-in

##### Energy input

Electric

##### Type of control

Electronic

##### Grill grating material

Cast iron

##### Required niche size for installation (HxWxD)

105 x 360 x 492

##### Width of the product (mm)

380

##### Dimensions of the product (mm)

105 x 380 x 520

##### Net weight (kg)

26.0

##### Gross weight (kg)

29.0

##### Residual heat indicator

Separate

##### Location of control panel

Hob front

##### Basic surface material

Cast iron

##### Color of surface

Stainless steel, Stainless steel

##### Color of frame

Stainless steel

##### Approval certificates

CE, ROSTEST, VDE

##### Length electrical supply cord (cm)

#### Consumption and connection features

##### Electrical connection rating (W)

3000

##### Gas connection rating (W)

Current (A)

16

##### Voltage (V)

220-240

##### Frequency (Hz)

60; 50

2016-10-04

Page 1

Installation with appliance cover/spacer batten;  
installation standing proud of surrounding surfaces

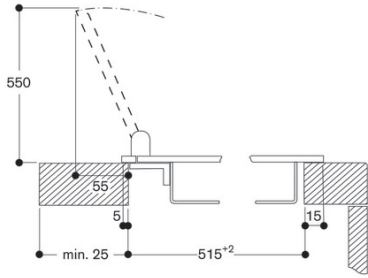

Installation with appliance cover/spacer batten;  
installation flush with surrounding surfaces

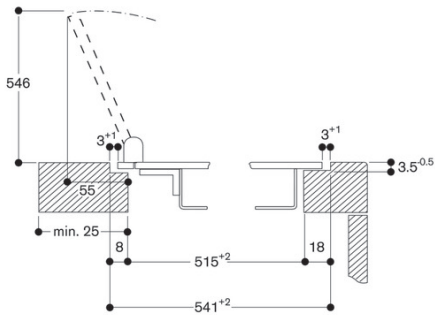

View from above

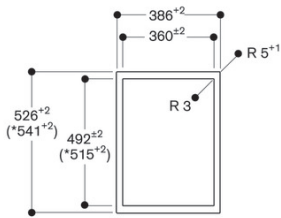

\* with appliance cover or filler strip  
(observe the front and rear asymmetrical support,  
see separate notes "Installation with appliance  
cover/filler strip").

Cross-section

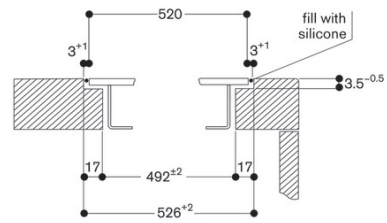

When installing with appliance cover or filler strip, pay attention  
to the deeper cut-out and the front and rear groove width.

Longitudinal section

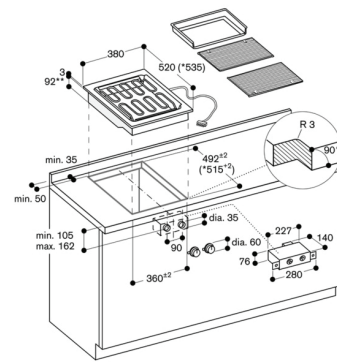
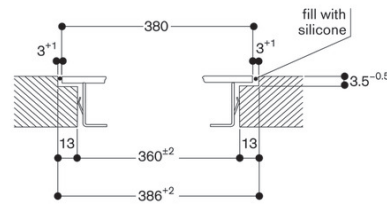

\* with appliance cover or spacer batten.  
See separate planning notes.  
\*\* 102 mm in the area of the cable clip (right, centre).

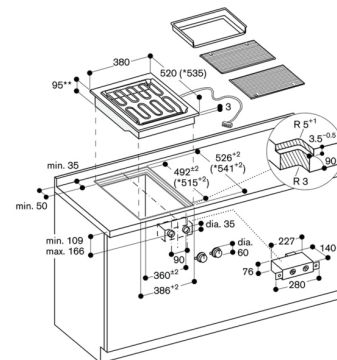

\* with appliance cover or filler strip.  
See separate planning notes.  
\*\* 105 mm in the area of the cable clamp (right, centre).