



Perfect Display For
All Your Favourites

Quality, Design and Innovation

WKb 4612



LIEBHERR

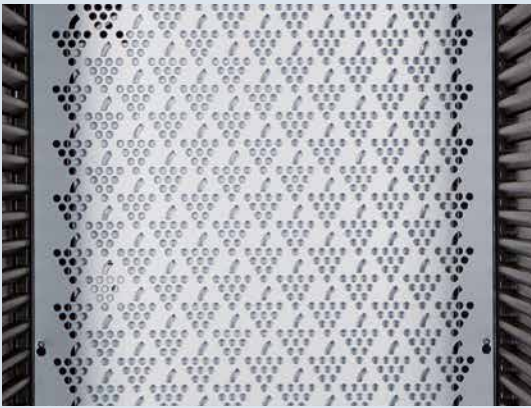

Optimum humidity: Liebherr wine cabinets guarantee an optimum humidity and this ensured the corks are supple in place whilst still allowing the wine to breathe in its maturing process.



LED lighting: The tinted glass door provides not only a perfect UV protection, but also an optimum glance at wine. The integrated LED lighting ensures a pleasant illumination of the complete interior.



Presentation shelf: The presentation shelf, equipped with wooden angles, is ideal for presenting wine and storing open bottles safely. Up to 6 bottles can be set upright on the flexible shelf. In addition further bottles can be stored lying down either behind or at the side.

Note: Whilst every effort is made to ensure all specifications and information in this flyer are accurate, Liebherr reserves the right to make changes without notification. Where actual appliance measurements, specifications, and ratings are crucial, we recommend that the actual appliance installation instructions that accompany each appliance be checked. Liebherr will not be liable for any loss.

The interior of Liebherr's **WKb 4612** wine cabinet from the Barrique series has a constant temperature that can be set as needed between +5 °C to +20 °C. Wines are stored safely at all times on untreated wooden shelves while the activated charcoal filter provides optimal air quality. With the capacity to hold 195 Bordeaux bottles, this spacious model is ideal for the long-term storage and maturation of wines. And thanks to its coated glass door, your prized collection is always well protected from UV radiation. Efficient LED lighting ensures that the interior is illuminated evenly and pleasantly. Add-on accessories¹ are also available for added flexibility.

WKb 4612	LED	Wine
Barrique		
°Energy consumption (kWh/yr) 24hr	°204 0.558	
Bottle capacity (750ml Bordeaux)	195	
Safety glass door	•	
Control system Display	Buttons Digital	
Digital temperature display	External	
Tinted glazed door	Double	
Temperature zones	1	
Temperature range (°C) Min Max °C	5 20	
Suitable for ambient temperature Min Max°C	10 43	
Interior light	Vertical LED	
Hand crafted beech wood shelves	6	
Presentation shelf Base shelves	Integrated 1	
Recirculated air cooling Fresh air supply via activated charcoal filter	• 1	
Child proof lock (control panel)	•	
Handle design	Black plastic	
Key lock Label holders	• •	
Temp alarm Door open warning signal	• •	
Door hinge	Right, reversible	
Gross weight (kg) Net weight (kg)	96 86	
Voltage (V) Rated Current (A)	220-240 1.0	
Made In	Malaysia	

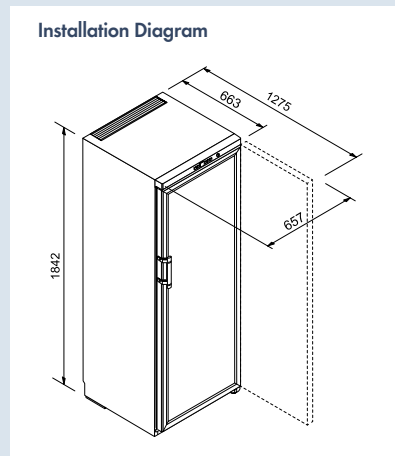

Activated Charcoal Filter
Part no.: 3988129100

° = Measurements taken at +25°C ambient and +12°C interior temperature tested by Liebherr Germany (not to Australian standards).

¹ Optional accessories: Activated Charcoal Filter (Part no: 3988129100)