

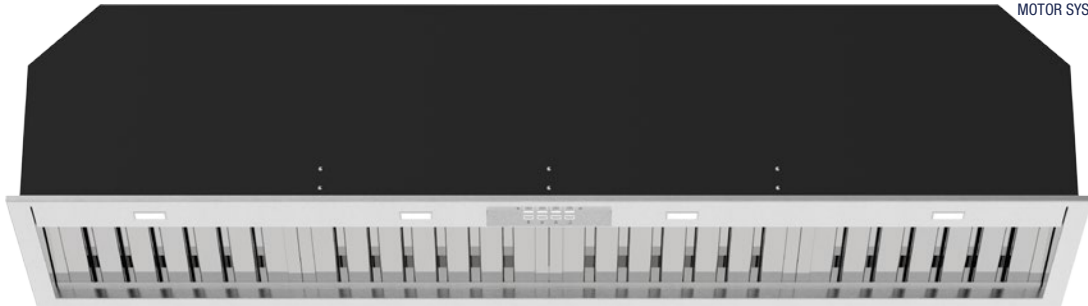

PROUDLY AUSTRALIAN OWNED  
DESIGNED & ASSEMBLED IN MELBOURNE



PREMIUM GERMAN MADE  
MOTOR SYSTEMS



- Model Number** X3MD16S
- Hood Mounting** Built In (Undermount) - Flush or Proud Install
- Cooking Coverage** Suits 120cm - 170cm Cooking Surfaces
- Filtration** S-Flow Baffle Filters 4x (H-25) - Dishwasher Safe
- Lighting** LED 4x (Warm White 1.0W) - Front Panel
- Finish** **AISI304 1.2mm** Food Grade Stainless Steel
- Controls** LED Backlit 4 Button *mastermind* Electronic Control with LED Speed Indicator
- Speed Settings** 3 Speed + Boost Mode
- Timer Function** Programmable Timer (10min Increments)  
Auto fan shut off after 2-hours of inactivity
- Outlet** "Twin" Top or Back Duct Outlets
- Ducting (Remote)** Dia. 200mm Acoustic Flexi Ducting - Five (5) Meter Length (Supplied)
- Ducting (On Board)** Optional On Board Motor Ducting Kits Available  
Ultra Motor - Dia. 200mm (Recommended)  
Power Motor - Dia. 150mm (Recommended)
- Hood Width** 1560mm
- Hood Depth** **380mm**
- Hood Height** 330mm (Top Duct Outlet - Plus 25mm)
- Installation Height** 700 - 750mm\* (Recommended)  
600mm\* (Minimum)  
\* Clearance above the highest point of the cooktop to the underside of hood

**Your Hood. Your Colour. Your Way.**

Available Finishes (Stainless Steel Finish Standard)

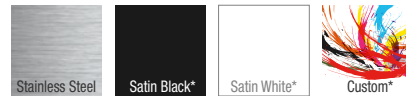

**Dimensioned Drawing**

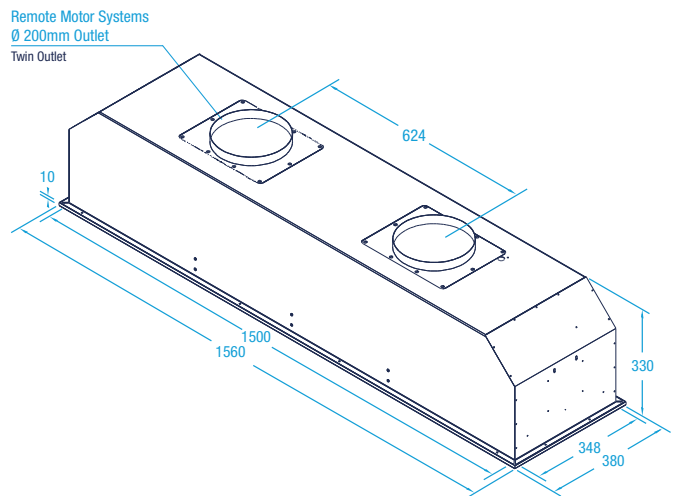

**Available Models - Select Your Motor Solution & Optional Finish**

*Remote External (Roof or Wall Mounted)*

- X3MD16S5.2EP "Twin" Pro 1,140m<sup>3</sup>/hr SPL: 49.6dB(A) In / 58.5dB(A) Out
- X3MD16S5.2EPP "Twin" Pro Plus 2,010m<sup>3</sup>/hr SPL: 56.6dB(A) In / 62.8dB(A) Out

*Remote Inline (Through Wall or Eave)*

- X3MD16S5.2IP "Twin" Pro 1,140m<sup>3</sup>/hr SPL: 49.6dB(A) In / 58.5dB(A) Out

*Your Hood. Your Colour. Your Way. (Optional Undermount Finish)\**

- X1P3.BL Paint Finish - Satin Black
- X1P3.WH Paint Finish - Satin White
- X1P3.CUS Paint Finish - Custom Colour

*\*Additional charges apply*

SPL - Nominal Sound Pressure Level on Boost (Max) Speed



**Whispair Endurance Warranty**



**Filtration Zone**

